Wireless Development Centre
Global Positioning System Receiver
(GPSR)
OEM General Specification

Dataset Name: GSPX26AB
Document Status: Approved
Stream: 01 Issue: 02
Issue date: June 10, 1998
Security status: Proprietary
Author: Claude Bedard

DISCLAIMER:

Refer to the Revision History section of this document for information about the status of this document. Any hard-copy of this document or unlocked softcopy must be regarded as an uncontrolled copy.

PROPRIETARY:

The information contained in this document is the property of Northern Telecom. Except as specifically authorized in writing by Northern Telecom the holder of this document: (1) shall keep all information contained herein confidential and shall protect same in whole or in part from disclosure and dissemination to all third parties and (2) shall use same for operation and maintenance purposes only.

© 1997 Northern Telecom Limited
All rights reserved

This page intentionally left blank

Publication history

The latest controlled release of this document is located in PAS under the Dataset Name. Please check PAS for the latest stream and issue of this document.

All other soft and hard copies are uncontrolled.

It is the responsibility of the reader to ensure that the latest release of this document is being used. Approval Record

The following staff are designated as key reviewers of this document:

Function	Printed Name	Dept
Originator	Feng Gao	2M23
GPSTM Prime	Claude Bedard	2M22
BTS System	Mike Claggett	2M26
BSC System	Jordan Mott	2Q92
OEM Module Integrity	Mike Shalla	0S42
Regulatory	Keys Low	2M55
Power and Grounding	Ed Norman	0M95
Mechanical Engineering	Ilan Vardi	2M25
Component Engineering	Curtis Cadrain	W477
Test Engineering	Greg Julian	W830
Software	Vinay Mahendra	2N15

The release of this document has been reviewed and approved for distribution and use by the following:

Function	Printed Name	Dept
Originator	Claude Bedard	2M23
Design Prime	Rick Kerlake	2M23

Revision History

Stream/Issue	Revision Date	Reason for Change	Author/Department
00/01	March 3, 1997	Creation of document.	Claude Bedard 2M22
00/02	March 21, 1997	Update to define holdover test cycle	Claude Bedard 2M22
00/03	April 18, 1997	Update to remove documents tests that would add unnecessary cost to the product	Claude Bedard 2M22
00/04	May 9, 1997	Add Nortel document naming convention and implement changes agreed to between HP and Nortel in April 30, 1997 meeting	Claude Bedard 2M22
00/05	August 12, 1997	Transpose document onto Nortel template; extend the operating temperature to 0 to 70 deg C; add some Nortel, regulatory and change management contents	Feng Gao 2M22
00/06	Oct. 7, 1997	Update the contents after the GS review	Feng Gao 2M22
00/07	Oct. 22, 1997	Consolidate the review inputs from OEM Integrity Group and Power Grounding Group, Update mechanical drawings	Feng Gao 2M22
00/08	Feb 6, 1998	Add the internal status registers bit assignments section and update the SCPI commands based on the review on Jan 28, 98; Update the temperature spec from 0 - 70 deg C to 0 - 50 deg C as the ambient air temperature.	Feng Gao 2M22
00/08	Feb 13, 1998	Include Nortel CDMA base station GPSR/GPSTM Serial Interface Spec in the SCPI commands section as a core command set Update the power hysteresis spec, include high/low voltage turn-on and turn off. Add an alternate spec for power supply hysteresis.	Feng Gao 2M23

Stream/Issue	Revision Date	Reason for Change	Author/Department
00/09	March 16,1998	Update the Interface Specification to include the interface connector identifications, Update the label requirements in the Product Marking Section, and Preparation for Delivery Section. Add the requirements for operation manual and field commissioning tool.	Feng Gao 2M23
00/09	March 30,1998	Include Nortel CDMA Base Station GPS Receiver/GPS Timing Module Serial Interface Specification into the GS.	Feng Gao 2M23
00/09	April 2,1998	Update the mechanical drawings and SPR CLEI labels location	Feng Gao 2M23
01/01	April 15,1998	Switch the SPR and CLEI label location on the mechanical drawing; Correct the unit of the spurious level to dBc/Hz; Add the Receiver I/O J3 Pin 1 as cable shield in Table 5 based on HP GPSR connection Update the stream and issue to 0D GS	Feng Gao 2M23
01/02	June 10,1998	Correct the vertical location of the threaded ground hole on the mechanical drawing from 0.713" to 0.653"	Claude Bedard 2M23

Major revisions will be marked by a change bar on the left of the table. The WDC OP and PI prime maintains the original signed copy of this document (including previous issues) for 3 years.

Preface

This document describes the general specifications of the cost reduction version of Global Positioning System Receiver (GPSR). The GPSR will be designed to operate in current Nortel CDMA Base Station Transceiver Subsystem (BTS) and Base Station Controller (BSC).

Any errors or omissions should be referred to the author so that these errors can be corrected in future issues of this document.

Table of Contents

Publication history.....	3
Revision History.....	4
Preface	6
Table of Contents.....	7
List of Figures	11
List of Tables.....	12
Related Documents	13
Glossary.....	15
1.0) Design Requirements	16
1.1) Scope.....	16
1.2) General Product Architecture.....	16
2.0) General Description	17
2.1) Principal Functions.....	17
2.2) Feature List	17
2.3) Backward Compatibility.....	17
2.4) Product Identification	17
3.0) Block Diagram and Partitioning	18
3.1) Block Diagram.....	18
3.2) Functional Block Descriptions	18
4.0) Mechanical Specifications	19
4.1) General	19
4.2) Construction and Design.....	19
4.3) Outer Dimensions	19
4.4) Weight.....	22
4.5) Interface Specifications.....	22
4.5.1) Interface Connector Identification	23
4.6) Module Chassis Enclosure	24
4.7) Cooling.....	24
4.8) Surface Treatments	24
4.9) Product Marking.....	24
4.9.1) General Requirements	25
4.9.2) Product Identification Marking - Rear Vendor Identification label	25
4.9.3) Serial/PEC/Release (SPR) Label.....	26
4.9.4) Common Language Equipment Identifier (CLEI) Label	27
4.9.5) Regulatory Label	27
4.9.6) Warranty Void Label.....	28
4.10) Grounding Strategy.....	28
4.11) Shielding Strategy.....	28
5.0) Electrical Specifications	29
5.1) General	29
5.1.1) Operating Conditions	29
5.1.2) Absolute Maximum Conditions.....	30
5.1.3) Modes of Operation.....	31

5.1.3.1) Operational Modes	31
5.1.3.2) Power Up Mode.....	32
5.1.3.3) Normal Mode	32
5.1.3.4) Holdover Modes	33
5.1.3.4.1) Auto Holdover Mode	33
5.1.3.4.2) Manual Holdover Mode.....	33
5.1.3.5) Recovery Mode	33
5.1.4) Receiver I/O Connector Definition.....	34
5.1.5) Power Connector Definition	35
5.1.6) 10 MHz Output (CDMA System)	36
5.1.6.1) Spurious Outputs.....	37
5.1.7) 10 MHz Reference Output (J2)	38
5.1.8) 1 PPS Output (CDMA System)	39
5.1.9) Serial Interface	41
5.1.9.1) Physical Layer	42
5.1.9.2) Communication Protocol	43
5.1.9.3) Serial Interface Message Description.....	43
5.1.9.3.1) Time of Day Query.....	46
5.1.9.3.2) Reset Receiver Command.....	47
5.1.9.3.3) Receiver Identification Query.....	47
5.1.9.3.4) Set/Get Receiver Position.....	47
5.1.9.3.5) Set/Get Satellite Elevation Mask Angle	48
5.1.9.3.6) Set/Get Antenna Delay	48
5.1.9.3.7) Set Survey Mode	48
5.1.9.3.8) Set Manual Holdover Mode	48
5.1.9.3.9) Set Manual Holdover Recovery	48
5.1.9.3.10) Holdover Duration Query	48
5.1.9.3.11) List of Satellites being Tracked.....	48
5.1.9.3.12) List of Predicted Satellites in View.....	48
5.1.9.3.13) Disable Tracking of Specific Satellites.....	48
5.1.9.3.14) Enable Tracking of Specific Satellites.....	49
5.1.9.3.15) Enable LED.....	49
5.1.9.3.16) Immediate Synchronization Command.....	49
5.1.9.3.17) Time Interval Query	49
5.1.9.3.18) Receiver Language Query.....	49
5.1.9.3.19) Frequency Figure of Merit Query.....	49
5.1.9.3.20) Survey Progress Query	49
5.1.9.3.21) Clear Error Queue	49
5.1.9.3.22) Log Data Query	50
5.1.9.3.23) Clear Log Entries Command	50
5.1.9.3.24) Log Entries Query.....	50
5.1.9.3.25) Operation Status Register Query.....	50
5.1.9.3.26) Lifetime Counter Query.....	50
5.1.9.3.27) Repeat Last Response Request.....	50
5.1.9.3.28) Antenna System Interface Query.....	50
5.1.9.3.29) Port Initialization	50
5.1.9.4) GPSR Internal Register Bit Assignments	50

5.1.9.5)	Software Error Detection	51
5.1.9.6)	Firmware Download	51
5.1.9.7)	GPS Week Rollover/Year 2000	52
5.2)	Input Power	52
5.2.1)	Input Voltage and Power	52
5.2.2)	Start-up/Turn-off	52
5.2.2.1)	Supply Characteristics	54
5.2.2.2)	Surge Current	54
5.2.2.3)	Input Overcurrent Protection	54
5.3)	Antenna Interface	55
5.3.1)	Antenna Unit	55
5.4)	Front Panel LED Indicators	55
5.5)	Other	56
6.0)	Environmental Specifications	58
6.1)	Temperature Range	58
6.2)	Humidity Range	58
6.3)	Altitude	58
6.4)	Operational Vibration Endurance	58
6.5)	Fungus Resistance	58
6.6)	Shipping and Storage	59
6.6.1)	Temperature and Thermal Shock	59
6.6.2)	Humidity	59
6.6.3)	Packaged Drop	59
6.6.4)	Unpackaged Installer/Service Drop	59
6.6.5)	Shock Fragility	59
6.6.6)	Transportation Vibration	59
6.6.7)	Transportation Bounce	59
7.0)	Electromagnetic Environment	60
7.1)	Radiated Emissions (Non Regulatory)	60
7.2)	Conducted Emissions	60
7.3)	Indirect Electrostatic Discharge Immunity	60
7.4)	Direct Electrostatic Discharge Immunity	60
7.5)	Electrical Fast Transient	60
7.6)	Radiated Immunity	61
7.7)	Conducted Immunity	61
7.8)	Lightning Protection	61
8.0)	Regulatory Requirements	62
8.1)	General	62
8.2)	Electromagnetic Interference	62
8.2.1)	Radiated Emissions	62
8.3)	Product Safety	62
8.4)	Materials Flammability	62
8.5)	Regulatory Submission and Maintenance	62
9.0)	Quality Assurance and Qualification	64
9.1)	General	64
9.2)	Vendor Supplied Data	64
9.3)	Production Test Plan	64

9.4) Product Qualification Tests	64
9.4.1) Test Methodology to Verify Holdover Capability	64
9.4.1.1) Holdover Test 1	65
9.4.1.2) Holdover Test 2	66
9.5) Acceptance Testing	68
9.6) Traceability.....	68
9.7) Reliability Monitor.....	68
9.8) Design Inspection	68
9.9) Workmanship Evaluation	69
10.0) Preparation For Delivery.....	70
10.1) Packaging	70
10.2) Product Packaging Label	70
10.3) Operation Manual	70
10.4) Commissioning Tool	71
11.0) Product Changes	72
12.0) Reliability Assurance	73
12.1) Reliability.....	73
12.2) Eliminating Infant Mortality Failures	73
12.3) Statistical Product Monitoring	73
12.4) Field Performance Monitoring.....	73
12.5) Product Reliability Growth.....	73
12.6) Yield Improvement Program	74

List of Figures

Figure 1: GPSR Block Diagram	18
Figure 2: GPSR Outer Dimensions	21
Figure 3: GPSR Front Plate Dimension and Mounting	22
Figure 4: Back Plane Connectors Identification	24
Figure 5: Date Code Label	26
Figure 6: Regulatory Label	27
Figure 7: Warranty Void Label	28
Figure 8: GPSR Operational Modes	31
Figure 9: Power Connector Orientation	35
Figure 10: 10 MHz Differential Pseudo-ECL Configuration	37
Figure 11: Fixed Spurious Levels	38
Figure 12: 1 PPS Differential Pseudo-ECL Configuration	41
Figure 13: Received Data Example	43
Figure 14: Input Voltage and Power Hysteresis, GPSR (+27V Input)	58
Figure 15: Input Voltage and Power Hysteresis, GPSR (-54V Input)	59
Figure 16: Temperature Cycle for Holdover Test 1	71
Figure 17: Temperature Cycle for Holdover Test 2	73

List of Tables

Table 1: GPSR Product Identification	17
Table 2: GPSR Interface.....	23
Table 3: GPSR Operating Conditions	29
Table 4: GPSR Absolute Conditions.....	30
Table 5: Receiver I/O Connector Definition (J3)	35
Table 6: Power Connector Pin-out (J4).....	35
Table 7: 10 MHz Output Requirements (CDMA SYSTEM).....	36
Table 8: 10 MHz Reference Output	39
Table 9: 1 PPS Output Requirements.....	40
Table 10: Serial Interface Physical Layer Requirements	43
Table 11: Serial Interface Message Description	46
Table 12: GPSR Operation Status Register	51
Table 13: Input Voltage and Power.....	54
Table 14: Front Faceplate LED Indicators	56
Table 15: Other Requirements, GPSR	57

Related Documents

The following documents, of the issue in effect on the date of purchase order, form part of this specification to the extent specified herein:

- [1] Network Equipment - Building System, Generic Equipment Requirements, Bellcore GR-63-CORE, Issue 1, October 1995.
- [2] Reliability Prediction Procedure for Electronic Equipment, Bellcore Technical Advisory TA-NWT-000332, Issue 5, September 1992.
- [3] Generic Requirements for Electronic Equipment Cabinets, Bellcore Technical Advisory, GR-487-CORE, Issue 1, June 1996.
- [4] Electromagnetic Compatibility and Electrical Safety Generic Criteria for Network Telecommunication Equipment, Bellcore, GR-1089-CORE, Issue 1, November 1994.
- [5] General Requirements of OEM Material, NPS50561 General specification, Issue 3.
- [6] FCC, Part 15 of Title 47, Code of Federal Regulations, Title 47 - Telecommunications, Part 15
- [7] Electromagnetic Compatibility Requirements and Test Methods for Telecommunication Equipment and Systems, TAD 8465, Issue 1, April 1992.
- [8] NT Standard 9101.01, Product Safety Reference Data.
- [9] Safety of Information Technology Equipment, UL 1950, Third Edition, CAN/CSA-C22.2 No. 950-95, Third Edition.
- [10] Underwriter Laboratories (UL) Standard UL94.V1.
- [11] ASTM D2863-77 Oxygen Index.
- [12] Electromagnetic Compatibility for Electrical and Electronic Equipment, Part 5: Surge Immunity Requirements, IEC 801-5.
- [13] CISPR Publication 22, First Edition 1985, Second impression 1991, International Special Committee on Radio Interference.
- [14] EIA-TIA-422-B, 1993, Electrical Characteristics of Balanced Voltage Interface Circuitry
- [15] Can/CSA-C22.2, No. 950-95, Safety of Information Technology Equipment, Including Electrical Business Equipment, A National Standard of Canada.
- [16] NT 9009.01, BNR/NT Global Limits for System Electromagnetic Compatibility.
- [17] Electromagnetic Compatibility For Industrial-Process Measurement and Control Equipment, IEC 801-2, Part 2: Electrostatic Discharge Requirements.
- [18] Electromagnetic Compatibility For Industrial-Process Measurement and Control Equipment, IEC 801-4, Part 4: Electrical Fast Transient/Burst Requirements.
- [19] Basic Environmental Testing Procedures, Tests A: Cold, IEC 68-2-1, fifth edition, 1990.
- [20] Basic Environmental Testing Procedures, Tests B: Dry Heat, IEC 68-2-2, Second Impression, 1987.

- [21] Basic Environmental Testing Procedures, Tests Ca: Damp Heat Steady State, IEC 68-2-3, Second Impression, 1985
- [22] Basic Environmental Testing Procedures, Tests N: Change of Temperature, IEC 68-2-14, fifth edition, 1984.
- [23] Basic Environmental Testing Procedures, Tests Ea: Shock, IEC 68-2-27, third edition, 1987.
- [24] Global Positioning System Standard Positioning Service Signal Specification, 2nd Edition, June 1995.
- [25] Synchronization Interface Standard, ANSI T1.101-1994.
- [26] Standard Commands for Programmable Instruments (SCPI), Version 1994.0.
- [27] EIA/TIA-232-E Interface Between Data Terminal Equipment and Data Circuit-Terminating Equipment Employing Serial Binary Data Interchange.
- [28] EIA-485 Standard for Electrical Characteristics of Generators and Receivers for Use in Balanced Digital Multipoint Systems, April 1983.
- [29] BTS Light Gray MT11030 Textured, Baked Organic Finish, Nortel NPS Finish 2023, Issue 2.
- [30] Basic Environmental Testing Procedures, Tests Ee: Bounce, IEC 68-2-55, first edition, 1987.
- [31] Industry Canada, Interference-Causing Equipment Standard - Digital Apparatus, Issue 2, Revision 1, January 1st, 1996
- [32] Nortel Corporate Standard 1517.00, Label and Marking.
- [33] Nortel Corporate Standard 5014.00, Serialization Codes for Telecommunications Products.
- [34] Nortel Serial Number PEC Release Drawing #3298-01a.
- [35] Nortel Three-Part Faceplate Label #3297-01a.
- [36] Nortel Corporate Standard 9017.00, Vendor Labels.
- [37] Nortel Procurement Specification NPS-90963, CLEI Bar Code Labels.
- [38] Bellcore TR-ST5-00383
- [39] Nortel CDMA Base Station GPS Receiver / GPS Timing Module Serial Interface Specification PLS MTXDOC gpsintsp.aa03 (or latest version).

Glossary

Term/Abbreviation	Meaning
CDMA	code division multiple access
CPC	common product code
BTS	base station transceiver subsystem
BSC	base station controller
FRC	frequency reference card
UUC	universal controller card
PPS	pulse per second
C	Celsius
EMC	electromagnetic compatibility
ESD	electrostatic discharge
GPSR	global positioning system receiver
GS	general specification
LNA	low noise amplifier
m	metre
ms	millisecond
ns	nanosecond
OEM	original equipment manufacturer
PCS	personal communication system
RF	radio frequency
SPR	serial/PEC/release code
V	volts

1.0 Design Requirements

1.1 Scope

This general specification describes a new cost reduction variant of the GPSR that is to replace the existing versions of the GPSR used in the Nortel CDMA product. This document is intended for the use of prospective vendors to prepare submissions to Nortel in the procurement process of the GPSR.

The GPSR operates within the CDMA BTS and BSC subsystem to provide the timing and frequency reference. The timing and frequency reference signals from the GPSR are synchronized to the Global Positioning System satellite constellation via a dedicated active antenna that amplifies the 1575.42 MHz +/-1.023 MHz (L1) carrier^[24].

Although it is not mandatory at this time, the capability to use the geostationary Wide Area Augmentation System (WAAS) satellite signal (spread spectrum signal also centred about the 1575.42 MHz L1 carrier) is permitted (when the WAAS system becomes operational).

1.2 General Product Architecture

The Nortel CDMA systems have both Cellular and PCS applications in an indoor or outdoor environment. The BSC is operated in a indoor environment; the BTS is intended to operate indoor or outdoor for the PCS range of 1830 - 1990 MHz, indoor for the cellular range of 824 - 894 MHz.

There is one GPSR within the BTS, two GPSRs within the BSC. It is intended to be a stand-alone module capable of supplying the frequency and timing reference signals.

2.0 General Description

2.1 Principal Functions

1. The GPSR provides 10 MHz frequency outputs to the FRC card.
2. The GPSR provides 1 PPS timing outputs to the FRC card.
3. The GPSR provides a serial interface to the UCC card.
4. The GPSR provides a 10 MHz reference output.
5. The GPSR provides an antenna input to power the active antenna and receive the GPS satellite constellation L1 carrier signal.

2.2 Feature List

1. Off-shelf configuration to accommodate current Nortel CDMA applications.
2. Frequency, timing, and serial interface ports for test and synchronization purposes.

2.3 Backward Compatibility

The GPSR is intended to be backward compatible in terms of internal firmware functionality within the CDMA system.

2.4 Product Identification

The Nortel PEC code that is assigned to the GPSR is shown in the following table.

Product Description	Product Engineering Code	Common Product Code	Notes
Global Positioning System Receiver	NTPX26AB Rel xx	A0681922	1

Table 1: GPSR Product Identification

Note 1: Nortel procurement will provide the current release.

3.0 Block Diagram and Partitioning

3.1 Block Diagram

A high-level block diagram describing the connectors, indicators, and I/O signals is shown in Figure 1.

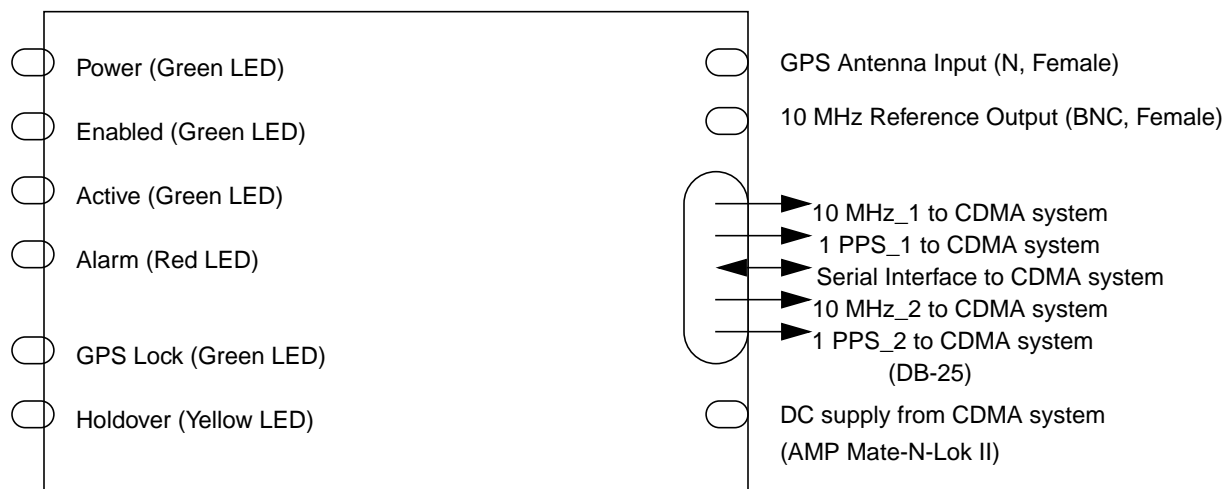

Figure 1: GPSR Block Diagram

3.2 Functional Block Descriptions

Not Applicable

4.0 Mechanical Specifications

4.1 General

The following section provides the mechanical specifications for the GPSR.

4.2 Construction and Design

Once this specification has been finalized, it shall be the responsibility of the GPSR supplier to direct questions relating to this specification to the Nortel purchasing department for resolution.

4.3 Outer Dimensions

The GPSR supplier shall comply with the module dimensional requirements as shown in Figure 2. The front plate dimension and mounting is illustrated in Figure 3.

Figure 2: GPSR Outer Dimensions

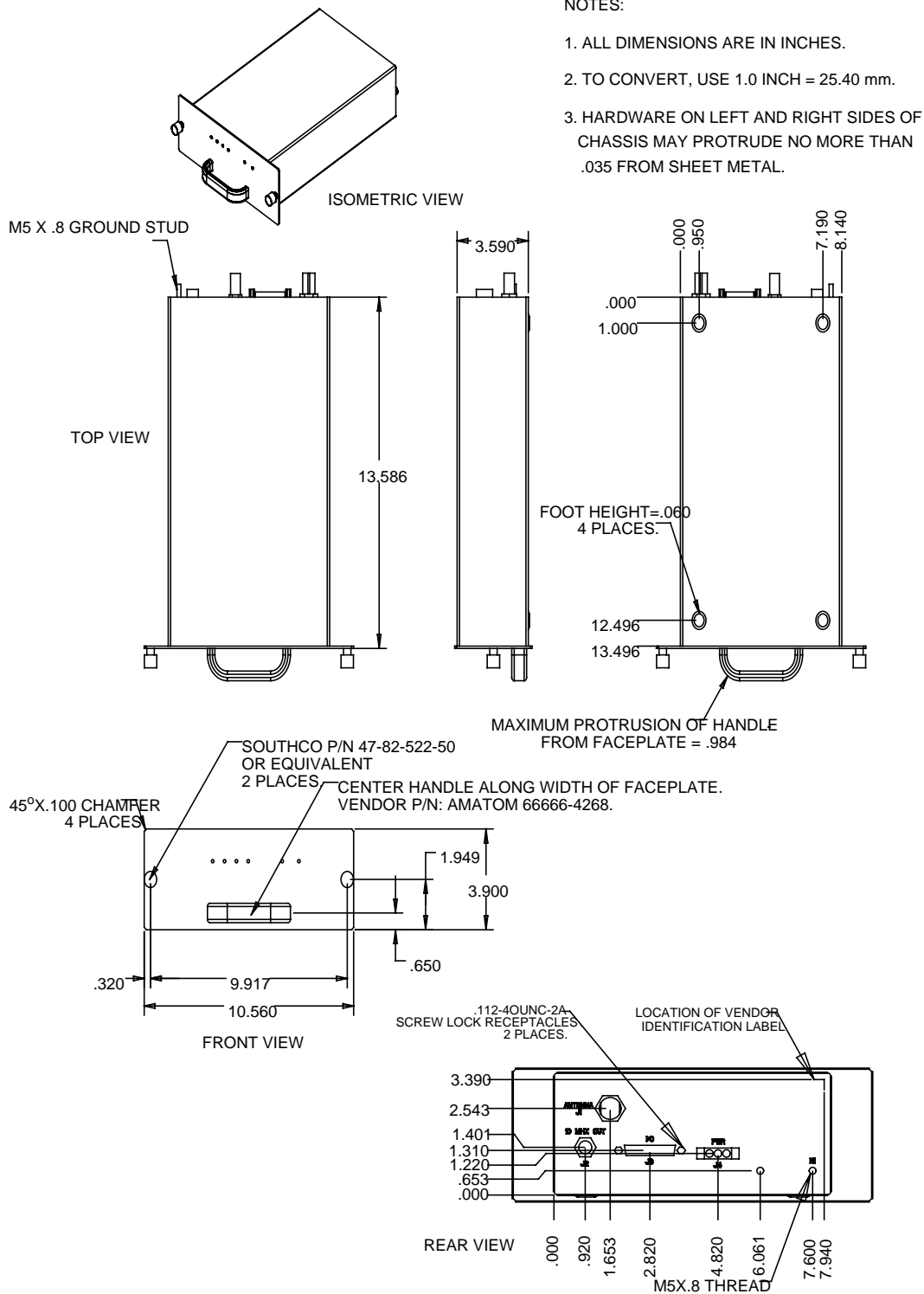
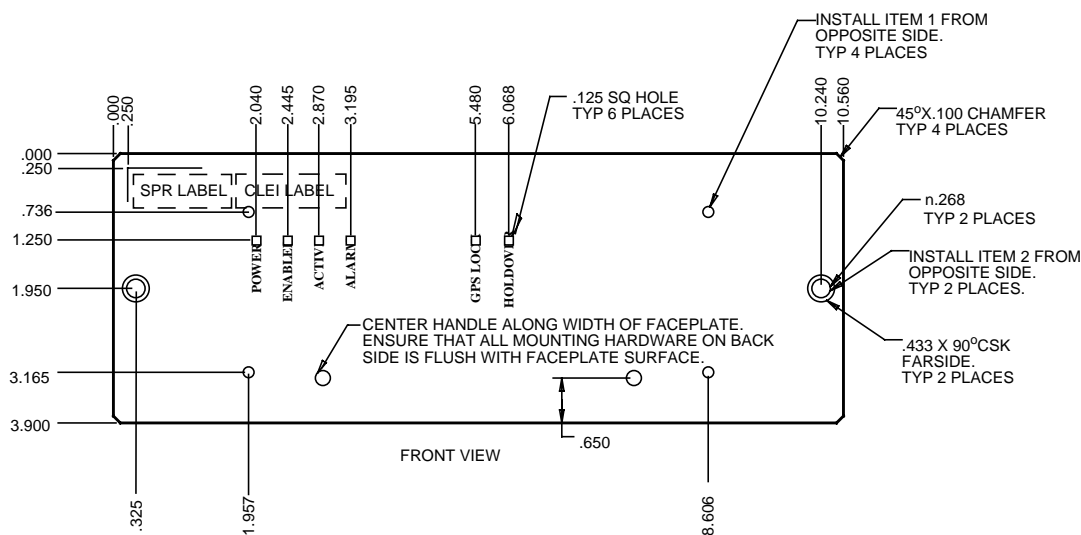

Figure 3: GPSR Front Plate Dimension and Mounting



BILL OF MATERIALS			
ITEM #	QTY	DESCRIPTION	SUPPLIER
1	4	WELD STUD M4 X 0.7 X 8.0 LG OR EQUIVALENT	ERICO JONES CO. OR EQUIVALENT
2	2	FASTENER, RETRACTABLE SCREW	47-82-522-50 SOUTHCO OR EQUIVALENT

4.4 Weight

The GPSR shall not exceed 3.6 kg (8 lbs).

4.5 Interface Specifications

The various interfaces of the GPSR and their associated connectors are described in the following table.

Interface	Connector	Signal(s)	M/F	Ref. Des.	Notes
Antenna	Type N	GPS Signal & Power Supply to antenna and in-line amplifiers	F	J1	1
10 MHz Reference	Type BNC	See Table 8	F	J2	1
Receiver I/O	DB-25	See Tables 5	F	J3	1, 2
Power Supply	AMP Mate-N-Lok II	See Tables 12	M	J4	1
Ground Stud	M5 by 20 mm	Chassis Ground	N/A	E1	
Threaded Ground Hole	M5	Chassis Ground	N/A	N/A	

Table 2: GPSR Interface

Notes:

1. Located on the rear panel of the module. Lockable connectors shall be used. All connectors shall include both functional and “J” reference designation markings.
2. The timing and frequency outputs and the serial interface to the CDMA system are via a single DB-25 connector with English screw lock captive hardware.

4.5.1 Interface Connector Identification

All RF connectors, DC power supply, I/O interface connectors are identified as shown in the following figure. The reference designations and approximate location for placement are also given in the figure, precise location is at the discretion of the vendor with Nortel Component engineering approval.

The edges of characters, borders and other markings shall be clean cut and as free from feathering as good commercial practise will permit. Loops and small openings in characters shall be open and distinct. Silkscreening is preferred.

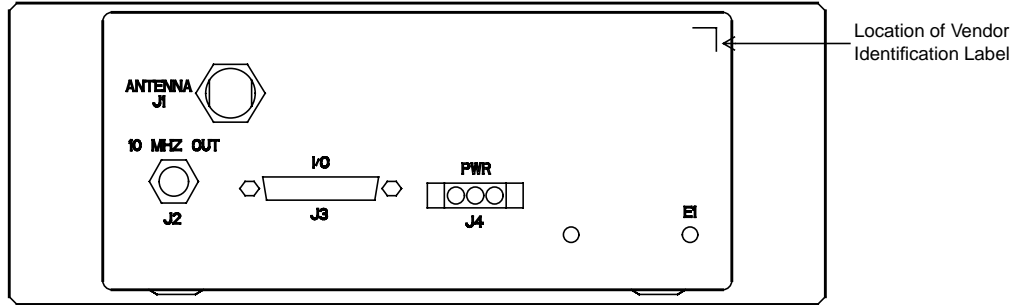

Figure 4: Back Plane Connectors Identification

4.6 Module Chassis Enclosure

It is at the discretion of the vendor, subject to meeting the product requirements specified in the GS.

4.7 Cooling

The unit shall utilize convection cooling. No internal fans are allowed within the GPSR. The front and rear will be the only surfaces with unobstructed air flow. The unit shall be capable of operation in the presence of air flow at 200 linear feet per minute.

4.8 Surface Treatments

All metallic surfaces of the receiver shall be protected from corrosion by the application of suitable plating or conversion coatings. The rear surface of the faceplate shall be left unpainted and the front handle shall have a black corrosion-resistant finish such as anodize or equivalent.

The front panel finish shall follow the Reference [29]

4.9 Product Marking

Product Identification Marking will be silkscreened directly onto the GPSR module.

Files containing silkscreening information for the front and rear of the GPSR module will be sent to the vendor via electronic mail.

The warning and manufacturing labels shall be affixed using a pressure sensitive adhesive. Any adhesive which is found to secure the labels permanently during the product life is acceptable. Artwork shall be plotted with a minimum resolution of 1200 dots per inch. It shall be the responsibility of the GPSR supplier to obtain details of the Nortel Corporate Logo from the Nortel purchasing department. All label designs shall be submitted to Nortel for approval prior to production. Label specifications are as follows unless described otherwise in the relevant section.

4.9.1 General Requirements

When screen printing, text should be in black characters using an appropriate size (That is: 12 point to 16 point) UNIVERSE 67 font. Adhesion of printed or stamped text must be such that it does not flake when tested in accordance with ASTM D3359, Method B.

Labels (if used) are to be white or silver polyvinyl chloride or equivalent material, 0.010 inch thick with black text. Labels must be applied in an aesthetically pleasing manner, square with the edges of the unit, free of bubbles and wrinkles, and in a consistent location. Labels shall be UL Recognized "Marking and Labeling Systems" and CSA Certified "Adhesive Type Nameplates", suitable for adhesion to the surface upon which they are applied. Regulatory labels (For example: UL, CSA logos) shall be applied in accordance with the requirements of the Agency, and are the responsibility of the supplier.

Refer to Nortel Corporate Standard 1517.00, Labels and Marking. All product labelling shall be procured from a UL-approved vendor.

4.9.2 Product Identification Marking - Rear Vendor Identification label

The rear product identification label for the GPSR will include:

- Vendor model number (arbitrarily by the vendor).
- Vendor product serial number (arbitrarily chosen by the vendor), compliant to the guidelines defined in Nortel Corporate Standard 5014.00, Serialization Codes for Telecommunications Products.
- Nortel Common Product Code (A0681922), compliant to the guidelines defined in Nortel Corporate Standard 1517.00, Labels and Marking.
- Nortel Product Engineering Code (NTPX26AB), compliant to the guidelines defined in Nortel Corporate Standard 1517.00, Label and Marking.
- Nortel Current Release (Rel XX), compliant to the guidelines as defined in Nortel Corporate Standard 1517.00, Labels and Marking, where XX is a two-digit number assigned by Nortel Component Engineering.
- Product manufacturing date code. This label shall indicate the week and year of manufacture of the GPSR, which is shown in the following figure. The week format shall follow the Nortel week calendar for the given year. Refer to Nortel Corporate Standard 1516.00, Product Date Codes for additional guidelines.

YYWW

Figure 5: Date Code Label

- Description of part: GPSR Dual Polarity

The approximate label location suggested by Nortel is shown in Figure 4. The specific rear panel location, orientation, and size of the label is at the discretion of the vendor, subject to approval by Nortel Component Engineering. Use Nortel Corporate Standard 1517.00, Labels and Marking, Section 4.5 as guidelines.

4.9.3 Serial/PEC/Release (SPR) Label

The Serial/PEC/Release (SPR) bar code label is used for asset and product management by Nortel. The label is made up of human and machine readable codes detaining the serial number, PEC code, and Release number. The label shall be affixed to the left bottom of the front faceplate of the GPSR module shown in Figure 3. A hash mark shall be printed on the front panel to indicate the SPR label location.

The following are the minimum requirements for the SPR label:

1. Nortel Serial Number PEC Release drawing #3298-01a

- Serial Number as per Nortel Corporate Standard 5014.00, Serialization Codes for Telecommunications Products.

- Serialization unique identifier as per Nortel Corporate Standard 5014.00, Serialization Codes for Telecommunications Products (not the same as the rear label serialization number as defined by the vendor). The identifier for the GPSR shall be NNTMvvvxxxxx, where vvv shall be the 3-digit vendor specific code as assigned by Nortel Component Engineering and xxxxx shall be the 5-digit alpha-numeric code assigned by the vendor (unique to each GPSR).

- Nortel Product Engineering Code (NTPX26AB), compliant to the guidelines defined in Nortel Corporate Standard 1517.00, Labels and Marking, followed by Nortel Current Release (XX), compliant to the guidelines defined in Nortel Corporate Standard 1517.00, Labels and Marking, where XX is a two-digit number assigned by Nortel Component Engineering. Refer to Nortel Serial Number PEC Release Drawing #3298-01a.

2. Optionally, the vendor may adopt the Nortel WNC 3-Part Label (#3297-01a). This is available from Nortel Component Engineering upon request.

4.9.4 Common Language Equipment Identifier (CLEI) Label

The CLEI bar code label is used to meet Bellcore customer requirements as defined in Bellcore TR-ST5-00383. The label is made up of human and machine readable codes detailing a Bellcore-assigned product identifier. The label shall be affixed to the left bottom of the front faceplate of the GPSR module as shown in Figure 3.

The following are the minimum requirements for CLEI label:

1. Refer to Nortel procurement Specification NPS-90963, CLEI Bar Code Labels for aesthetic guidelines.
2. Refer to Nortel 3-part Faceplate label (Blank), Drawing #3297-01a, for dimensioning purposes.
3. The CLEI label content shall be provided to the vendor by Nortel Component Engineering.

4.9.5 Regulatory Label

The Regulatory information shall be affixed to the rear panel of the GPSR chassis along with the Rear Vendor Identification Label. The label shall contain the information specified by UL, and the minimum contents shall be presented as the following figure.

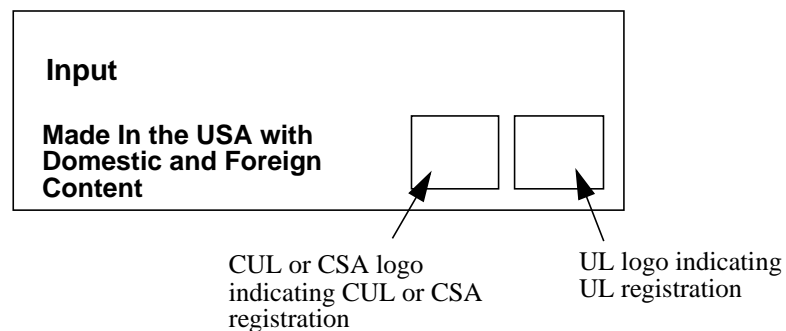

Figure 6: Regulatory Label

The specific rear panel location, orientation, and size of the label is at the discretion of the vendor, subject to approval by Nortel Component engineering. Use Nortel Corporate Standard 1517.00, Labels and Marking, Section 4.5 for reference.

4.9.6 Warranty Void Label

The Warranty Void Label shall be affixed over a screw head or package joint so that the label must be removed to gain access to the internal portion of the module. Any material and adhesive combination which ensures destruction of the label upon removal is acceptable. An example of label content is shown in the following figure.



Figure 7: Warranty Void Label

4.10 Grounding Strategy

- The shield of the coaxial connectors will be grounded to the GPSR chassis.
- Logic Return is the return side of all secondary power supplies within the GPSR. These returns shall be tied together at some point within the GPSR and connected to the GPSR chassis ground. (Thus, logic return and chassis ground are connected within the module.)
- The GPSR shall be designed to work with dual supplies (-54 V, +27 V). The external power supply return shall not be connected to chassis ground; it shall remain isolated from chassis ground via the CDMA system power supply.
- The chassis ground connection shall be brought out via the ground stub E1 at the backplane, as denoted in Table 2. To minimize emissions from the ground system the digital ground plane should be tied to the chassis ground.

4.11 Shielding Strategy

It is at the discretion of the vendor to achieve the best result of EMI performance.

5.0 Electrical Specifications

5.1 General

The following section provides the electrical specifications for the GPSR.

5.1.1 Operating Conditions

The GPSR shall start and operate within its electrical specifications over any combination of the following conditions:

Parameter	Minimum	Maximum	Notes
+27 V Supply Voltage	19.5V	30V	10
-54 V Supply Voltage	-60V	-36.5V	10
Supply Voltage Regulation		+/-1%	7
Supply Voltage Filtering		Voice band, <55dBnC	7
Supply Voltage Ripple and Noise		350 mV _{pp} (DC to 100 MHz)	7
Supply Voltage Dynamic Response		+/-5%	7
Supply Voltage Transients	0	-75V	8
Temperature	0°C	+50°C	1, 3
Temperature Rate of Change		+/-10°C/hour	
Relative Humidity	5%	95%	2
Altitude	-60m	4000m	
Load VSWR		Infinite	4
Maximum Acoustic Noise Level		see notes	5
Airborne Contamination		see notes	6
Air Flow	200 linear feet/minute		
Operational Vibration		see notes	9

Table 3: GPSR Operating Conditions

Note

1. Temperature is specified at the external ambient air temperature of the GPSR module.
2. Non-condensing; 100% R.H. shall be used as a design objective.

3. The maximum operational ambient temperature shall be reduced by 2°C for every 300 metres altitude above 1500 metres.
4. The GPSR shall not be damaged when the antenna cable is shorted (centre conductor to shield or centre conductor to ground) or left open with the receiver powered.
5. The GPSR shall operate in an environment with acoustic noise not exceeding that defined in GR-487 CORE requirement R3-157.
6. The GPSR shall operate in an environment with airborne contamination not exceeding that defined in GR-487 CORE requirement R3-158.
7. This specification applies to the output of the DC power supply within the Digital Enclosure.
8. The transient duration shall not exceed 1ms; the supply voltage shall not exceed 0 to +100Vpk for 10us.
9. The GPSR shall have no damage or loss of function while the CDMA system is being subjected to vibrations of magnitude 0.1 g peak acceleration applied over the frequency range 5-100 Hz in accordance with Bellcore GR-487-CORE requirement R3-171 and in accordance with Bellcore GR-63-CORE Section 4.4.3.
10. The GPSR shall operate in both +27 V and -54 V CDMA systems.

5.1.2 Absolute Maximum Conditions

The GPSR shall be capable of withstanding any of the following conditions without damage.

Parameter	Minimum	Maximum	Notes
Supply Voltage	-75V	+75V	3
Storage Temperature (Ambient)	-55°C	+85°C	
Altitude (Non-operating)	-60m	9000m	1
Relative Humidity	5%	95%	2
Load VSWR		Infinite	4

Table 4: GPSR Absolute Conditions

Notes:

1. Transport and/or storage.
2. Non-condensing; 100% R.H. shall be used as a design objective.

3. The GPSR shall not be damaged if the polarity on the power leads is reversed.
4. The GPSR shall not be damaged when the antenna cable is shorted (centre conductor to shield or centre conductor to ground) or left open with the receiver powered.

5.1.3 Modes of Operation

5.1.3.1 Operational Modes

The operational modes of the unit are shown in the following figure and described in the proceeding paragraphs. A “mode” of operation is defined by both the performance requirements of the mode and the circumstances causing a transition to the mode.

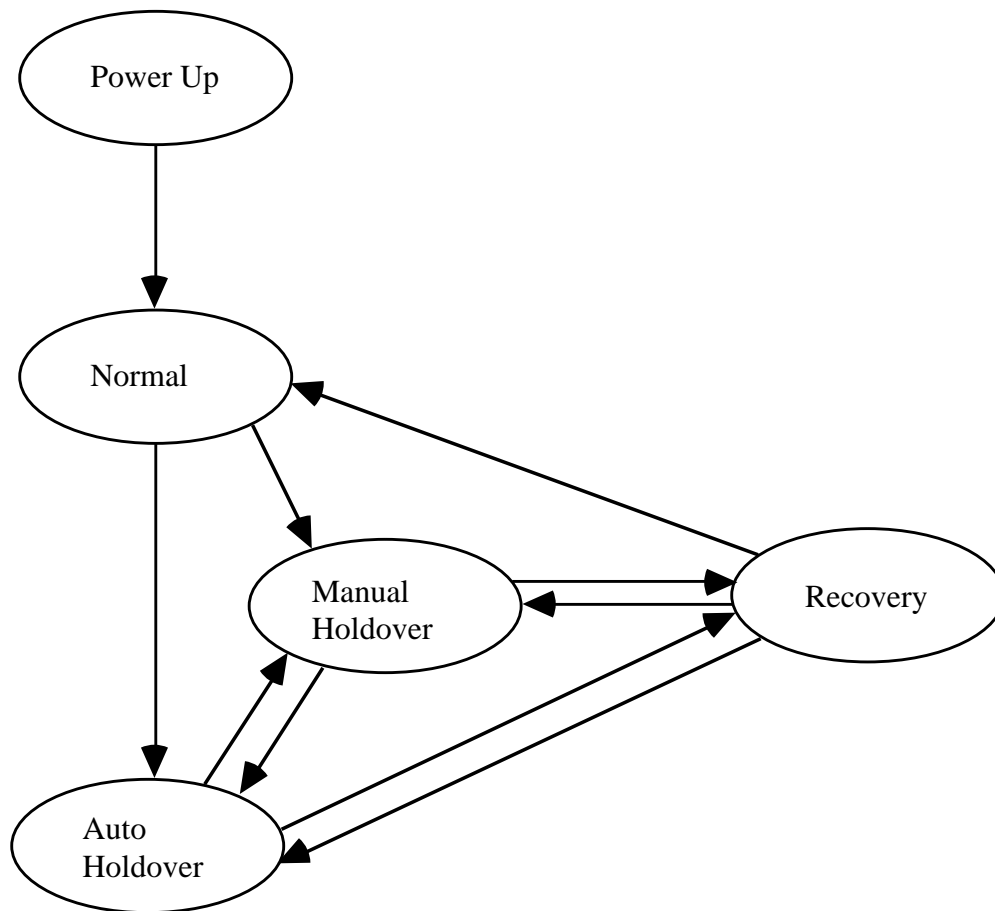

Figure 8: GPSR Operational Modes

5.1.3.2 Power Up Mode

Upon the application of power, the following occurs:

- Power LED is lit.
- Unit self test is performed. User observes LED is turned on one by one during the self test.
- All LEDs except Power LED is deactivated if self test is successful.
- 10 MHz Reference signal becomes available. The signal shall remain available while the GPSR is active, regardless of the operational mode.
- Serial Interface becomes available for operation.
- The oscillator begins to stabilize.
- GPS Constellation is acquired.
- Position is determined for the first power up after leaving the factory.
- The timing and frequency output signals are brought into agreement with GPS system time.

The GPSR will automatically determine its position only the first time it is powered on once it leaves the factory. All subsequent power ups will use the last position stored in the unit's memory. If a GPSR has been moved, it must perform a survey to determine its new location. A GPSR must automatically initiate the new survey no later than 30 minutes after power is applied if satellites are not tracked, provided that the GPSR is already in the "position hold" mode when power is applied. (This will eliminate the need to have a craftsman force a survey if the GPSR was not preset to original factory settings before leaving the Nortel factory.)

The GPSR shall acquire Lock in less than 60 minutes from the commencement of a survey (no current almanac, position or time, with four satellites in view for survey). This time shall also be met with the position set through the Serial Interface and a single satellite in view.

The unit transitions to the Normal mode of operation once its frequency and timing outputs are within the specifications for the normal operation. (This event can occur prior to the end of a survey, provided that the survey continues to complete and the unit's position is determined and stored in memory. Information can be provided via the Serial Interface to assist or to speed up this mode. One example is that the position can be entered so the time required for a survey is shortened. An approximate date, time, and position can be entered to speed up a survey.

5.1.3.3 Normal Mode

In the Normal mode of operation the unit is locked to GPS, its position is known and normal disciplining of the oscillator to GPS system time is taking place.

After a transition from Power Up mode, the unit's oscillator is in the initial stages of stabilizing. This is considered Normal mode of operation even though the unit cannot meet the 24 hour holdover requirement. Upon initial installation at a cell site, the GPSR shall meet the 24 hour holdover requirement after a 24 hour warm-up/training period. The GPSR will be permitted a 24 hour warm-up/training period in the event of a power loss and the 24 hour holdover requirement shall be met following this training period.

5.1.3.4 Holdover Modes

There are two holdover modes: Auto Holdover and Manual Holdover.

5.1.3.4.1 Auto Holdover Mode

The decision to transition into a Auto Holdover mode is determined by the unit. Reasons for this transition include:

- Loss of GPS lock (ie: due to impaired view of the sky causing temporary loss of the constellation or antenna system failure).
- The GPS signal becomes unbelievable (ie: a GPS satellite broadcasts faulty data).

If either of the above occurs, the unit must create the required frequency and timing signals on its own. The GPSR may rely solely on its internal oscillator for the timing and frequency signals. The GPSR continually monitors the GPS signal and tries to acquire a stable GPS signal. Once the unit determines that a stable GPS signal is available, it can transition over to the Recovery mode. Hysteresis shall be included in this decision making process to keep the unit from oscillating between Auto Holdover and Recovery modes for questionable GPS signals. There shall be a built-in delay of one minute before the GPSR indicates (via register) a switch to the Auto Holdover mode.

5.1.3.4.2 Manual Holdover Mode

A manual holdover occurs when commanded by the user. The unit must then create the required frequency and timing signals on its own. The GPSR may rely solely on its internal oscillator for the timing and frequency signals. The unit will remain in this mode until commanded otherwise. Once commanded out of this mode, the unit transitions to "Auto Holdover" mode to ensure the GPS signal is available and stable prior to a transition to Normal mode via Recovery Mode.

5.1.3.5 Recovery Mode

During the Recovery mode, the error between GPS system time and the unit's time is reduced to the normal steady state value. The error is dependent on the holdover period and the drift properties of the oscillator. During recovery the 1 PPS signal is allowed to be corrected by up to 101.725 ns in 200 milliseconds. (This specification is defined in EIA/TIA/IS-95, Section 7.1.5.2 and represents 1/8 PN chip.) The 10 MHz output must meet all specifications. When commanded by the user, an immediate synchronization to GPS constellation shall occur.

5.1.4 Receiver I/O Connector Definition

There are three major interface signal types: 10 MHz Output, 1 PPS Output, the Serial Interface. They are incorporated into a single DB-25 connector that is used to provide timing, frequency and communication information to the CDMA BTS and BSC. The Serial Interface will be used by the UCC to determine the health of the GPSR, the validity of the 10 MHz and 1 PPS Outputs, and to activate/deactivate LEDs on the front faceplate of the GPSR. As far as the Serial Interface is concerned, the GPSR is considered as Data Terminal Equipment (DTE). It shall be configured by the vendor to operate in a half-duplex mode. The serial data interchange (transmit data and received data) must conform to EIA RS-422A, EIA-404-A, and EIA-363 characteristics.

All I/Os (timing, frequency, and communication) shall be continually available (including during warm-up and holdover).

Signal Name	Pin Number	Comments
10 MHz_1	15 12	Differential pseudo-ECL GPSR output 10 MHz_1- 10 MHz_1+
1 PPS_1	17 9	Differential pseudo-ECL GPSR output 1 PPS_1- 1 PPS_1+
10 MHz_2	11 24	Differential pseudo-ECL GPSR output 10 MHz_2- 10 MHz_2+
1 PPS_2	8 21	Differential pseudo-ECL GPSR output 1 PPS_2- 1 PPS_2+
Transmitted Data	2 (A) 14 (B)	RS-422, GPSR output
Received Data	3 (A) 16 (B)	RS-422, GPSR input
Signal Ground	7	
Cable Shield	1	

Table 5: Receiver I/O Connector Definition (J3)**5.1.5 Power Connector Definition**

The power connector shall be a AMP Mate-N-Lok II, part number 770025-1. The contact shall be a pin, AMP contact number 770250-2. The connector pin assignment is given in Table 6. The connector shall be oriented vertically as shown in Figure 4.

Pin	Function
+27V (nominal) input	
Pin 1	+27V
Pin 2	no connect
Pin 3	Return
-54V (nominal) input	
Pin 1	Return
Pin 2	no connect
Pin 3	-54V

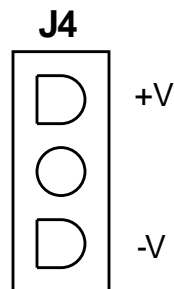
Table 6: Power Connector Pin-out (J4)**Figure 9: Power Connector Orientation**

5.1.6 10 MHz Output (CDMA System)

Table 7 shows the requirements on 10 MHz signal provided by the GPSR via J3 to the CDMA system.

Parameter	Requirement
Frequency	10 MHz
Frequency Accuracy	< 10 ⁻⁹ one day average
Phase Noise (as measured about the 10 MHz fundamental frequency)	-120 dBc/Hz max. at 100 Hz -135 dBc/Hz max. at 1 kHz -135 dBc/Hz max. at 10 kHz -135 dBc/Hz max. at 100 kHz -135 dBc/Hz max. at 1 MHz
Spurious	See Section 5.1.6.1
Isolation - between any of the 10 MHz outputs	> 60 dB
Waveform	Square Wave, duty cycle 40% to 60%
Level	Differential Pseudo-ECL

Table 7: 10 MHz Output Requirements (CDMA SYSTEM)

The recommended line driver for this signal is TBD. (If a Lucent 1141NG or equivalent substitute BPNGA16G-TR is selected, using a split termination. In this configuration, each signal line must have 220 ohms to ground as part of the GPSR design). This driver must be independent from the driver used for 1 PPS distribution to limit phase noise. The following figure shows the differential pseudo-ECL configuration. This circuit shall be used when performing measurements of the differential pseudo-ECL 10 MHz Output.

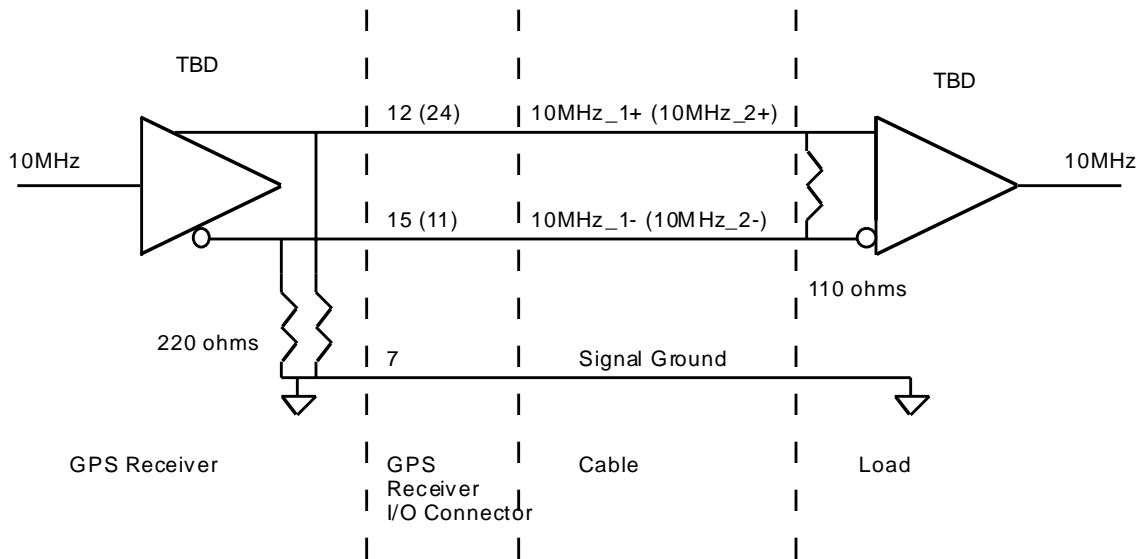

Figure 10: 10 MHz Differential Pseudo-ECL Configuration

5.1.6.1 Spurious Outputs

The 10 MHz output is used as a reference to generate critical signals in CDMA system. It is important that this signal be as spurious free as possible. It is acknowledged that due to the physical nature of the unit a certain level of spurious will exist. It is also understood that the level of spurious can be minimised by careful electrical and mechanical design.

No performance degradation is permitted for operational vibration. Spurious (due to internal or external noise or other mechanisms) shall be below the levels shown in the following figure for all operating conditions.

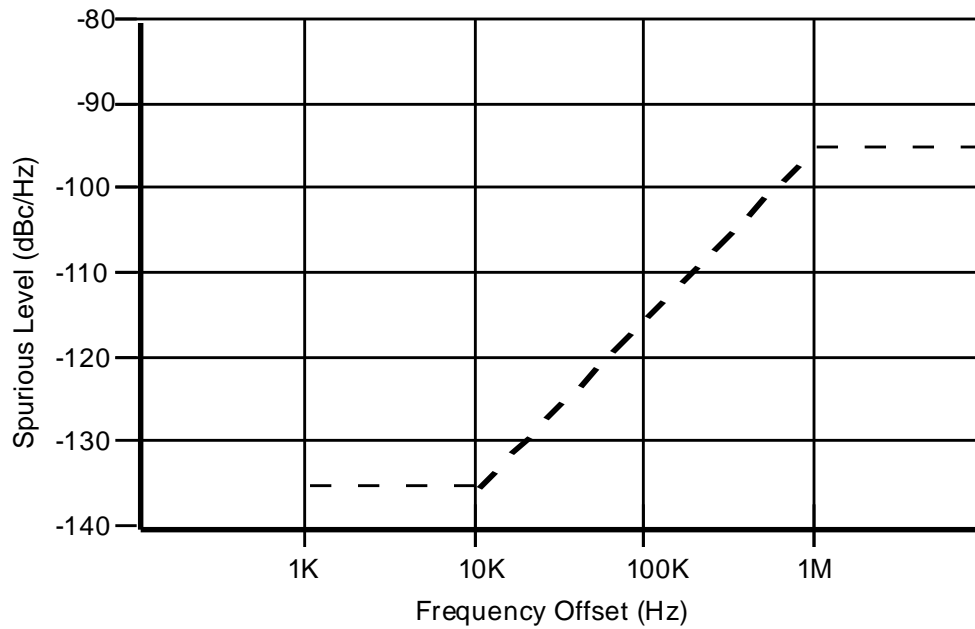

Figure 11: Fixed Spurious Levels

5.1.7 10 MHz Reference Output (J2)

This output is used for synchronizing test equipment to the GPSR output. The 10 MHz signal shall have the same parametric requirements as in Section 5.1.6 with the following physical interface.

Parameter	Requirement
Frequency	10MHz
Source Impedance	50 Ω nominal
Return Loss	1.8:1 VSWR maximum (-10.9 dB maximum)
Coupling	AC
Protection Terminating Impedance Voltage Reverse RF Power	∞ :1 VSWR, any angle maximum +/-50 V _{DC} maximum +20 dBm maximum
Waveform	Sine wave
Level	2.0 Vp-p +/- 0.5 V
Connector	BNC, female

Table 8: 10 MHz Reference Output

5.1.8 1 PPS Output (CDMA System)

The following table shows the requirements of the 1 PPS signal provided by the GPSR to the CDMA system via J3.

Parameter	Requirement
Frequency	1 Hz
Frequency Accuracy	Exactly once every 10×10^6 10 MHz clock cycles. The falling edge of 1 PPS shall occur 0-5 ns after the falling edge of 10 MHz clock.
Accuracy of “on-time” edge (receiver locked)	$\pm 1 \mu\text{s}$ traceable to and synchronous with Universal Coordinated Time (UTC) with at least one satellite in view. The error is due to calibration error, tolerance in measurement, position fix error and selective availability (SA) error.
Accumulated time error (all causes, aging, temperature etc.)	Less than $\pm 7 \mu\text{s}$ over a single, contiguous 24 hour period (unlocked, after the training period for hold-over operation). Refer to Section 5.1.3.3 for definition of the training period
Rate of Change for Timing Corrections	$\leq 101.725 \text{ ns per } 200 \text{ ms}$ (EIA/TIA/IS-95 requirement)
Jitter	No jumps in 1 PPS greater than 200 nsec between pulses. No sequence of jumps accumulating more than $\pm 1 \mu\text{s}$ per day (locked to the GPS constellation).
Waveform	Negative pulse, 10 to 50 us wide, leading edge defines on-time (falling edge)
Level	Differential pseudo-ECL

Table 9: 1 PPS Output Requirements

The recommended line driver for this signal is TBD. (If a Lucent 1141NG or equivalent substitute BPNGA16G-TR is selected, using a split termination. In this configuration, each signal line must have 220 ohms to ground as part of the GPSR design). This driver must be independent from the driver used for 10 MHz distribution to limit phase noise. The following figure shows the differential pseudo-ECL configuration. This circuit shall be used when performing measurements of the differential pseudo-ECL Output.

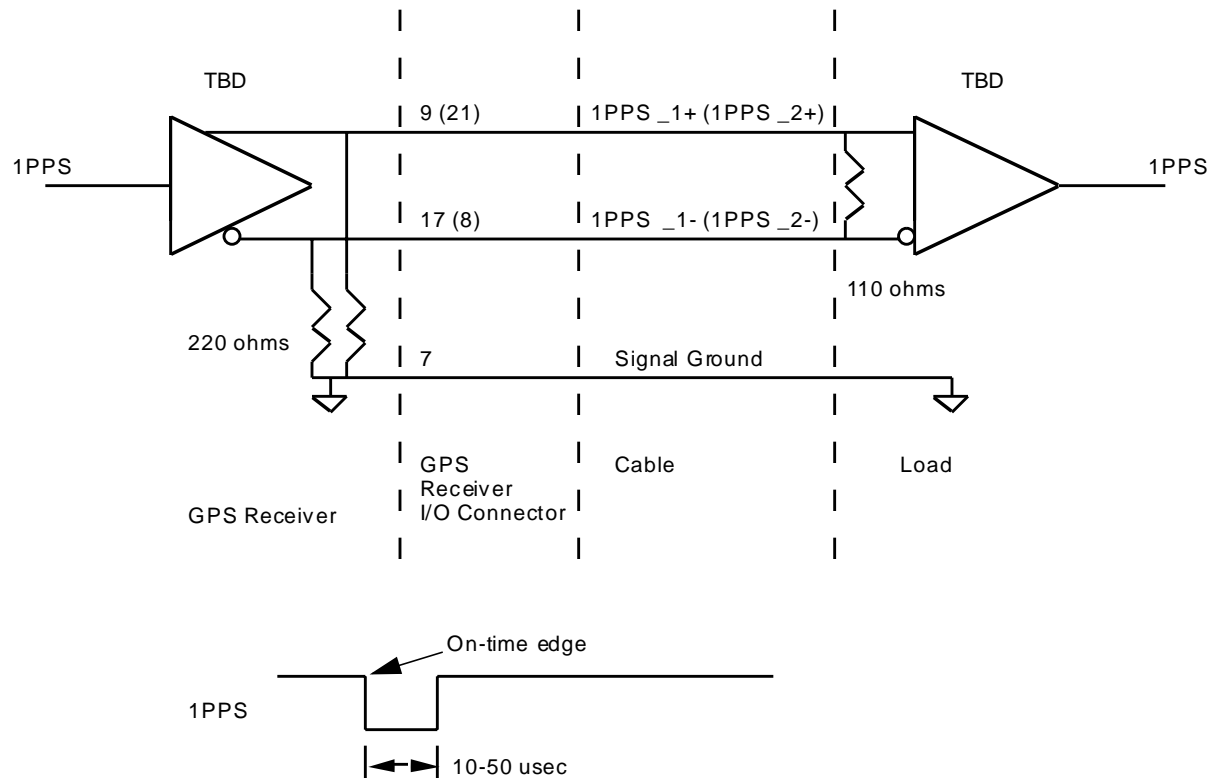

Figure 12: 1 PPS Differential Pseudo-ECL Configuration

5.1.9 Serial Interface

The serial interface provides a bi-directional interface for the purpose of performing the following main functions:

- Retrieving Time of Day information and leap second corrections.
- Status reporting such as alarm and mode notifications.
- Configuration of the receiver such as setting a precise location.
- Coordinating diagnostic tests.
- Manually overriding certain modes of operation such as forcing a survey mode.
- Firmware download.

Information can be passed in one of the following ways:

- Specific information can be sent to and returned by the GPSR by using specific commands (sent to the GPSR) or responses (from the GPSR).
- Significant events are recorded in a log in the GPSR. This log is accessed by using commands sent to the GPSR.
- Errors are stored as messages by the GPSR. These are accessed by using commands sent to the GPSR.
- The GPSR shall have minimum one Status Register to operate within our legacy CDMA software, which is the Operation Status Register. The other Status Registers are at vendor's discretion to include in the design, such as Hardware Status Register, Holdover Status Register, etc.

The manufacturer shall configure the serial interface so that the product in which the GPSR resides shall be able to communicate (with the GPSR or the user) in half-duplex mode.

A mask can be used with each register. This mask, which is set by a command, allows the user to define which items stored in the register are returned when requested.

The Serial Interface utilises a layered architecture. The physical layer is described in Section 5.1.9.1. Message descriptions are given in Section 5.1.9.3.

5.1.9.1 Physical Layer

The serial interface to the CDMA system (CM) is an RS-530 compatible interface consisting of the following signals.

- Transmitted Data
- Received Data
- Signal Ground

The following table lists requirements for the serial interface physical layer. Figure 11 shows an example of the Received Data physical interface.

Parameter	Requirement
Data Rate	19.2 kbps
Data Format	Asynchronous, 1 start bit, 1 stop bit, 7 bits per character and odd parity.
Data Communication Standard	RS-530 compatible. See EIA-RS-530, EIA-RS-422, EIA-363 and EIA-404-A.

Table 10: Serial Interface Physical Layer Requirements

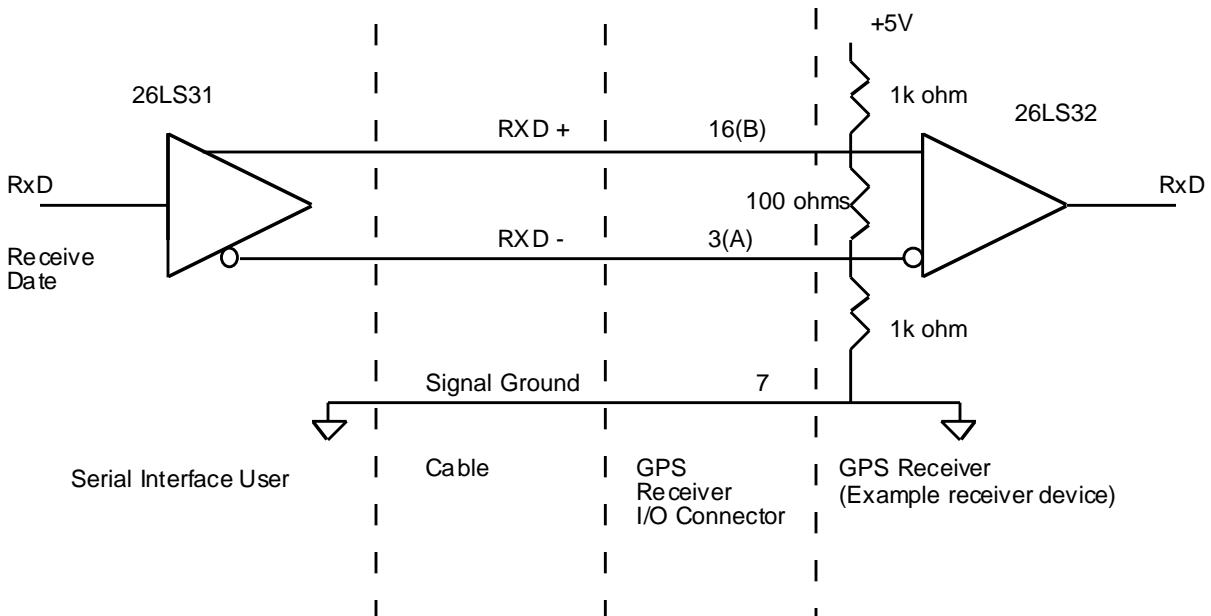

Figure 13: Received Data Example

5.1.9.2 Communication Protocol

The GPSR shall use the Standard Commands for Programmable Instruments (SCPI), V1994.0 communication protocol^[26] as a guideline, and follow Nortel internal specification Nortel CDMA Base Station GPS Receiver/GPS Timing Module Serial Interface Specification, which defines the detailed Communication Protocol and Message types used by our CDMA software. See the document ^[39] for further reference.

5.1.9.3 Serial Interface Message Description

The following table shows the list of message types that are exchanged over the serial interface. Any discrepancy found between the following section and Nortel CDMA Base Station GPS Receiver/GPS Timing Module Serial Interface Specification, use the Nortel internal specification as a govern document.

Some of these messages may be carried out in a series of command messages instead of in single messages. (Because this document is still in a DRAFT format, this message list is subject to change. A reduction in the number of messages is highly likely because several of the messages in this command set will soon be unavailable from some GPS engine manufacturers. These GPS engine manufacturers are reducing the features that are available to the end users.)

#	Command	Parameters/Response	Reference
1	Time of day query	returns: GPS time code	5.1.9.3.1
2	Reset receiver command	send: Sets unit into a known state.	5.1.9.3.2
3	Receiver Identification query	returns: Nortel CPC, PEC, release, Manufacturer, and revision information	5.1.9.3.3
4	Set/Get Receiver Position	send: Specific location, survey estimation returns: Location	5.1.9.3.4
5	Set/Get satellite elevation mask angle	send: Elevation mask angle in degree returns: Elevation mask angle in degree	5.1.9.3.5
6	Set/Get antenna delay	send: antenna delay in seconds returns: antenna delay in seconds	5.1.9.3.6
7	GPS survey mode	send: survey mode command return: indication if unit is in survey mode.	5.1.9.3.7
8	Set manual holdover mode	send: manual holdover mode command.	5.1.9.3.8
9	Set manual holdover recovery	send: recover from manual holdover mode command.	5.1.9.3.9
10	Holdover duration query	returns: holdover duration in seconds	5.1.9.3.10
11	List of satellites being tracked	returns: List of satellites IDs	5.1.9.3.11
12	List of satellites in view	returns: List of satellites that are over the horizon based on current time and position	5.1.9.3.12
13	Disable tracking of specific satellites, command or query	Send: List of satellite IDs returns: List of satellites IDs	5.1.9.3.13
14	Enable tracking of specific satellites, command or query	Send: List of satellite IDs returns: List of satellites IDs	5.1.9.3.14

#	Command	Parameters/Response	Reference
15	Enable LED, command or query	send: On/Off value returns: On/Off value	5.1.9.3.15
16	Immediate synchronization command	send: synchronize GPSR internal 1 PPS output with GPS constellation immediately (used during Recovery mode only)	5.1.9.3.27
17	Time interval query	returns: Time interval between the internal oscillator 1 PPS and GPS 1 PPS	5.1.9.3.17
18	Receiver language query	send: System language query returns: Primary or Install mode	5.1.9.3.18
19	Frequency figure of merit query	returns: frequency figure of merit (FFOM)	5.1.9.3.19
20	Survey progress query	returns: % completion of the survey process	5.1.9.3.20
21	Clear error queue command	returns: Error queue clear indication	5.1.9.3.21
22	Log data query	send: Log number to be read returns: Log string	5.1.9.3.22
23	Clear log entries command	send: clear the log	5.1.9.3.23
24	Log entries query	returns: Log count	5.1.9.3.24
25	Operation Status Register query	send: request numerical value of the Operation Status Register returns: contents of Operation register	5.1.9.3.25
26	Lifetime Counter query	returns: The current value in the lifetime counter	5.1.9.3.26
27	Return Last Response query	returns: last response sent by GPSR	5.1.9.3.27
28	Antenna System Interface query	returns: status of the Antenna Interface	5.1.9.3.28
29	Serial Port Initialization	sends: Initialize the Port returns: None	5.1.9.3.29

Table 11: Serial Interface Message Description

All messages sent by the GPSR are in response to the commands sent by the user. The following sections describe the functions and purposes of these messages in detail.

5.1.9.3.1 Time of Day Query

This command returns the timecode message 980 to 20mS (inclusive) prior to the 1PPS of indicated time. An example of the response is T1#H20AF16AC41+00B4. The message includes:

- T1 = Format identifier
- #H = Number representation identifier
- 20AF16AC = GPS time in seconds of the next 1PPS on-time edge.
- 4 = Time figure of merit (TFOM)
- 1 = Frequency figure of merit (FFOM)
- + = Leap second information. A '+' sign indicated a pending GPS leap second, while a '0' sign indicates no pending GPS leap second.
- 0 = Service Request
- 0 = Alarm indication
- B4 = Checksum

The format of GPS time is a 32-bit integer represented in HEX. The TFOM message defines the accuracy of 1PPS. A number between 0 and 9 represents a time error of 10^{TFOM-1} to 10^{TFOM} nanoseconds;

- 0 <1 ns
- 1 1ns to 10ns
- 2 10ns to 100ns
- 3 100ns to 1µs
- 4 1µs to 10 µs
- 5 10 µs to 100 µs
- 6 100 µs to 1 ms

- 7 1 ms to 10 ms
- 8 10 ms to 100 ms
- 9 >100 ms

5.1.9.3.2 Reset Receiver Command

This command returns the receiver to the following state:

- Returns the unit to the manufacturer's factory settings.
- The unit assumes the Power-up mode and starts to survey.

5.1.9.3.3 Receiver Identification Query

The GPSR returns the following information about its identification when requested:

- Nortel Common Product Code (CPC)
- Nortel Product Engineering Code (PEC)
- Nortel Release Number
- Manufacturer code
- Model number
- Serial number
- Firmware revision

5.1.9.3.4 Set/Get Receiver Position

This places the receiver in 'position hold' mode at the designated position. Used as a query, this returns the last 'position hold' location or the current position estimate if in a survey mode.

5.1.9.3.5 Set/Get Satellite Elevation Mask Angle

This sets or returns the elevation mask angle; 90° is straight up. The factory default setting is 10°.

5.1.9.3.6 Set/Get Antenna Delay

As a command, this sets the delay from the antenna unit to the receiver unit measured in seconds. As a query, this returns the delay from the antenna unit to the receiver unit measured in seconds.

5.1.9.3.7 Set Survey Mode

As a command, this forces the units into a survey state.

5.1.9.3.8 Set Manual Holdover Mode

This places the receiver in a holdover mode. The receiver will stay in this mode until commanded otherwise.

5.1.9.3.9 Set Manual Holdover Recovery

This commands the termination of the manual holdover mode; see Section 5.1.9.3.11.

5.1.9.3.10 Holdover Duration Query

The unit returns the length of time that the unit has been in a holdover mode. If not currently in a holdover mode, the unit will return the length of the last holdover mode; units are in seconds.

This message has two parts; the first, duration, has been described. The second indicates if the unit is in holdover at the time of the query.

5.1.9.3.11 List of Satellites being Tracked

The unit returns a list of satellite ID numbers (SVID) of the satellites currently being tracked by the unit. A "0" returned means no satellites are currently being tracked.

5.1.9.3.12 List of Predicted Satellites in View

The unit will return a list of satellites ID numbers (SVID) of the satellites predicted to be over the horizon. This prediction is based upon the almanac, date, time and position. If any of these are in error the prediction will be incorrect. A "0" returned means no satellites should be in view. The predicted satellites takes into account the elevation mask angle setting of the receiver.

5.1.9.3.13 Disable Tracking of Specific Satellites

This is a command/query. The unit can be commanded to ignore tracking specific satellites. When queried, the unit returns a list of satellite ID numbers (SVID) of satellites currently being ignored.

5.1.9.3.14 Enable Tracking of Specific Satellites

This is a command/query. The unit can be commanded not to ignore specific satellites. When queried, the unit returns a list of satellite ID numbers (SVID) of satellites not being ignored.

5.1.9.3.15 Enable LED

This is a command/query. This can be used to command the LED ON/OFF or to check the status of the LED.

5.1.9.3.16 Immediate Synchronization Command

This command allows the unit to immediately synchronize the 10 MHz reference and 1 PPS outputs to the GPS system. It is intended to be used when an extended holdover has occurred and once GPS lock has been re-achieved the time interval (TI, defined in Section 5.1.9.3.29) is either too large for proper system operation or the time required for normal correction to bring the TI within acceptable limit is too great.

5.1.9.3.17 Time Interval Query

The unit returns the difference (in seconds) between the output 1 PPS and the GPS system 1 PPS signals.

5.1.9.3.18 Receiver Language Query

This command query the GPS Receiver for what language enabled. 'INSTALL' for firmware downloading and 'PRIMARY' for normal operation.

5.1.9.3.19 Frequency Figure of Merit Query

The unit returns this value indicating the uncertainty of the 10 MHz output of the unit. This value is defined as:

- 0 - indicates that the output is stable; unit is locked.
- 1 - indicates that the output is stabilizing; unit is locked.
- 2 - indicates that the unit is unlocked and in holdover.
- 3 - indicates that the unit is unlocked but not in holdover (still in initial power-up).

5.1.9.3.20 Survey Progress Query

The unit returns the percent complete of the survey process.

5.1.9.3.21 Clear Error Queue

This command clears the error queue and returns a clear queue indication.

5.1.9.3.22 Log Data Query

The user sends log number to be read and the unit returns the contents of this register. An optional numeric parameter can be used to identify a specific log entry. If no numeric parameter is provided, the most recent log entry is returned.

5.1.9.3.23 Clear Log Entries Command

The unit clears the log.

5.1.9.3.24 Log Entries Query

This unit returns the number of entries in the log.

5.1.9.3.25 Operation Status Register Query

The unit returns a decimal content of the register.

5.1.9.3.26 Lifetime Counter Query

The unit returns the current value in the lifetime counter. This counter is initially zero at the factory and is incremented by one for every three hours of operation.

5.1.9.3.27 Repeat Last Response Request

This command is used in an error recovery process. The unit will return the last message that it had sent through the Serial Interface.

5.1.9.3.28 Antenna System Interface Query

This query returns a response from the GPSR that determines if there is an open/short on the antenna interface.

5.1.9.3.29 Port Initialization

The command sends a carriage return and a linefeed sequence to a GPS Receiver serial port. The Receiver response is none.

5.1.9.4 GPSR Internal Register Bit Assignments

Minimum one internal register shall be provided with a GPSR module, Operation Status Register. The bit assignments are shown in the following table.

Bit	Description in System Source Code	Usage in BTSC
1	Power up Status register	This summary bit not referenced by BTSC software.
2	Locked on Satellites Indicator	0: Not Locked (in Holdover); 1: Locked on satellites.
3	Holdover Indicator	This summary bit not referenced by BTSC software.
4	Position Hold Indicator	0: GPSR is in survey mode; 1: GPSR is in position hold mode.

Bit	Description in System Source Code	Usage in BTSC
5	Satellite View Indicator	0: Insufficient satellites in view; 1: Sufficient satellites in view.
6	Hardware Integrity Indicator	0: Working normally; 1: A hardware fault was detected.
7	Log Present Indicator	0: Log has sufficient room; 1: Log is almost full.
8-16	Unspecified	These bits not referenced by BTSC software.

Note: Bits 1, 3, and 6 are set based on the contents of other tables (i.e. if any hardware error bit is set in the hardware error table, bit 6 is set otherwise bit 6 is clear).

Table 12: GPSR Operation Status Register

5.1.9.5 Software Error Detection

If the receiver detects a syntax error while receiving a message from the user, the receiver increments the error count and ignores the entire message. The receiver does not respond to the user in any way. In such a case, the user is expected to re-send the original query to the receiver as a complete, separate message. If the GPSR receives a message with an unrecognisable header or an incorrect parameter format, it considers the message erroneous and does not respond to the message. Such messages in error do not affect the performance of the GPSR.

5.1.9.6 Firmware Download

The GPSR shall be capable of receiving a firmware download via the Serial Interface (J3) as a stand alone unit. The OEM vendor shall provide the capability to upgrade the firmware by a field commissioning tool, which is specified in the GS Section 10.4.

The OEM vendor is suggested to include the capability of flashing the firmware by SCPI commands via the Serial Interface (J3). However, it is not a must requirement at the time of writing the document.

5.1.9.7 GPS Week Rollover/Year 2000

The GPSR shall be designed in such a manner that upon expiration of GPS week 1023, the necessary conversions will be made in calculation of a calendar date from GPS time. Refer to the GPS SPS Signal Specification, 2nd Edition, Section 2.3.5. The GPSR shall also accommodate calendar dates in the year 2000 and beyond.

5.2 Input Power

There are two types of power sources that the GPSR is intended to work with. A given installation will only provide one type of power. Power will be supplied to the GPSR from a rectifier set that is constantly charging a bank of batteries and powering the equipment at the site. In the event of a mains failure, the equipment at the site (including GPSR) will operate from the batteries until the mains are restored or until battery voltage is out of the operating range. The GPSR shall be designed such that it can continuously operate in a stable condition at any supply voltage in the specified range for an indefinite period. This implies that if any device internal to the receiver is switched in or out as a function of supply voltage, the switching shall not introduce any transients which violate any requirement of the specification and hysteresis shall be utilised to keep the unit from oscillating between states under any combination of operating conditions.

When designing/specifying the DC-DC converters for GPSR, reference the Bellcore Technical Reference, TR-TSY-001003, Generic Requirements for Embedded DC-DC Converters as a design guide.

5.2.1 Input Voltage and Power

See Tables 3 and 4 for operational and absolute requirements. The GPSR shall be capable of operation from either a negative supply or a positive supply. The manufacturer shall employ a power supply that can accept either input voltage range described in Table 14.

5.2.2 Start-up/Turn-off

The GPSR shall include circuitry which will automatically activate and deactivate the unit as shown in the following figure. Since the CDMA system has various overvoltage and low voltage protection features which kick in around 20V and -60V DC, the GPSR high voltage shut-down voltage is specified at +/-61.5V with +/-1V tolerance; the GPSR high voltage restart is specified at 58.5V with +/-1V tolerance. The GPSR low voltage shut-down is specified at 18.5V with +/-1V tolerance; the GPSR high voltage restart is specified at 21.5V with +/-1V tolerance. (The aim of this section is to ensure that the GPSR will never shut down prior to the CDMA system due to low or high voltages at the power supply). Hysteresis shall be used as shown below.

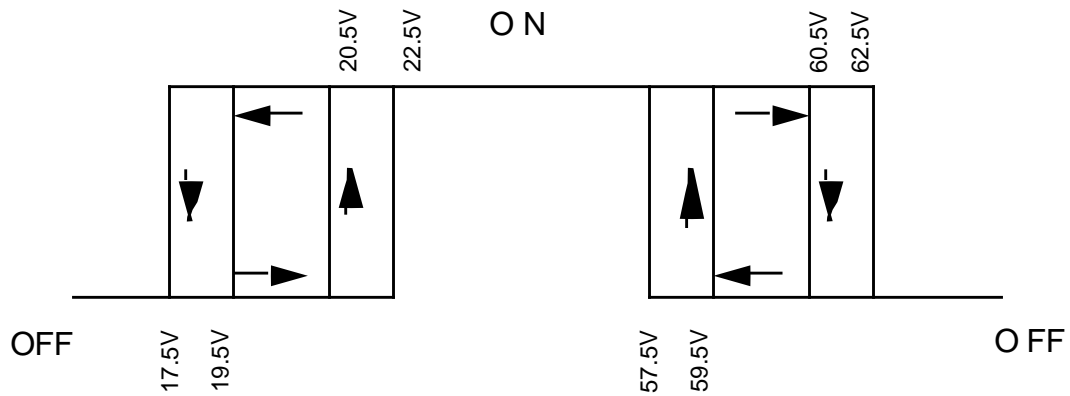

Figure 14: Input Voltage and Power Hysteresis, GPSR (+27V Input)

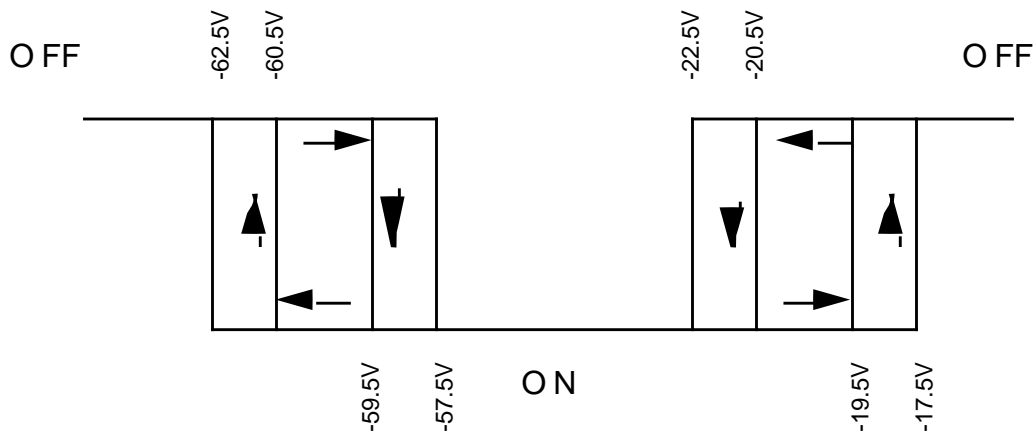

Figure 15: Input Voltage and Power Hysteresis, GPSR (-54V Input)

Table 13: Input Voltage and Power

Parameter	Requirement
+27V (nominal) input	
Turn-On (V_{on})	21.5+/-1 V
Turn-Off (V_{off})	18.5 +/-1V
Power during warm-up (approx. 15 min.)	75 Watts maximum
Power, normal operation	40 Watts maximum
-54V (nominal) input	
Turn-On (V_{on})	-21.5 +/-1 V
Turn-Off (V_{off})	-18.5 +/-1 V
Power during warm-up (approx. 15 min.)	75 Watts maximum
Power, normal operation	40 Watts maximum

Alternatively, the GPSR power supply hysteresis could be specified as follow:

- Shall start up between 23VDC and 57VDC and
- Shall operate (once started) between 20VDC and 60VDC and
- Shall not be damaged between 0 and over 75VDC (See also the transient spec).

Therefore the vendor could select their own power hysteresis thresholds based on their own design and accuracy limits as long as the module meets the above requirements.

5.2.2.1 Supply Characteristics

Refer to Section 5.1.1 for the specifications as applicable to the incoming DC power provided to the GPSR by the CDMA system.

5.2.2.2 Surge Current

The surge (in-rush) current shall not exceed 6 amps peak value.

5.2.2.3 Input Overcurrent Protection

A circuit breaker or fuse cannot be assumed in the DC supply lines to the unit; an internal fuse (5 amp, PCB mount) can be used. An internal (non-field replaceable) fuse shall blow only in the event of a catastrophic internal failure. Its purpose is to prevent fire and additional damage to the unit. The fuse shall not be field accessible.

The design of the GPSR shall prevent the internal fuse from blowing out in the case of reversed polarity of external power supply.

5.3 Antenna Interface

The Antenna Interface accepts the GPS signal from the antenna and supplies power via the center conductor for the antenna and in-line amplifiers. Antenna feed runs from 30 to 1000 feet are required. A single coaxial cable shall be used for all functions between the receiver and antenna, maximum coax diameter equivalent of RG-8. (LMR-400 is the preferred cable type). An in-line surge suppressor (Polyphaser IS-MR50LNZ+6) shall be used as close as possible to the point where the antenna cable enters the building. The use of in-line amplifiers, powered through the coaxial cable by the GPSR, is acceptable for runs in which the total antenna cable path loss exceeds 20 dB (cable length is dependent upon cable type).

The antenna interface output circuitry shall not be damaged if the output is shorted to ground for an indefinite period. The GPSR shall be capable of detecting an open/short on the antenna interface for troubleshooting purposes (information accessible via software interface). Once Lock has been initially achieved, detection of a problem on the antenna interface shall be included as a reason for the GPSR being in Holdover (Refer to Section 5.1.9.3.21).

5.3.1 Antenna Unit

The GPSR shall be expected to operate with the Aromat GPS-A-32-TNC-02-W (Matsushita CCA532ST02) antenna providing the RF input. This antenna requires a +5V +/-0.5V supply via the RF centre conductor. The RF cable shield shall provide the return path for the DC supply.

5.4 Front Panel LED Indicators

Front panel indicators shall consist of LEDs to report the status of the GPSR. The device status indicators are defined in the following table. The LEDs shall be positioned (from left to right) Power, Enable, Active, Alarm, space, GPS Lock, Holdover. The manufacturer's manual shall provide Nortel with the list of conditions that would illuminate the RED LED (internal hardware alarm conditions). All of the LEDs shall be mounted on the internal mother board.

Name	Color	Controlled by	Description
Power	Green	GPSR	The GPSR sets this state (LED ON) upon the application of power to the unit. Circuitry to control the LED shall be positioned after the input overcurrent protection.
Enabled	Green	User	The User commands the receiver to turn on or off the LED.
Active	Green	User	The User commands the receiver to turn on or off the LED.

Alarm	Red	GPSR/User	The GPSR or the User commands the LED on. Both the user and the GPSR must agree for the LED to be off.
GPS Lock	Green	GPSR	The GPSR sets this state (LED ON) when the unit has acquired and is tracking the GPS signal.
Holdover	Yellow	GPSR	The GPSR sets this state (LED ON) when the unit has gone into a holdover mode. The reason for going into a holdover mode is available via the Serial Interface.

Table 14: Front Faceplate LED Indicators

5.5 Other

The following table shows other requirements on the GPSR.

Parameter	Requirement
Acquisition Time (all outputs meet specified performance levels)	Less than 60 minutes from the commencement of a survey (no current almanac, position or time, with four satellites in view for survey). This time shall also be met with the position set through the Serial Interface and a single satellite in view.
Data retention	All settings for the unit must survive an indefinite power outage.
Simultaneous Satellite Processing	The GPSR is required to simultaneously track multiple satellites (when available). The data from the satellites shall be sanity checked as part of timing and/or frequency corrections.
Averaging	The affects of Selective Availability must be averaged out such that the requirements shown in Section 5 are met.
Continuous Outputs	The 10 MHz reference, 10 MHz Output, and 1 PPS outputs are to be continuously operational while the receiver is transferring between satellites, the antenna is being replaced, etc. The term “operational” means meeting all specifications in Section 5.
Multi-path	The receiver design must be able to combat multi-path when the antenna is mounted well below the roof line of adjacent buildings. (Example 7 floors).

Parameter	Requirement
Periodic Outages	The receiver must be able to operate with periodic GPS system outages. Many antenna placements will not afford a full sky view. Operational means meeting all specifications in Section 5.
Internal Batteries	Not Allowed

Table 15: Other Requirements, GPSR

6.0 Environmental Specifications

The GPSR shall be capable of meeting all electrical specifications over the following environmental conditions.

6.1 Temperature Range

The GPSR shall be capable of meeting all the electrical requirements outlined in Section 5 of this document over a temperature range of 0°C to +50°C. The maximum ambient temperature shall be reduced by 2 degrees C for every 300 metres altitude above 1500 metres.

The GPSR shall be able to start and operate properly at a high temperature of +50°C. High temperature test procedures are defined in IEC 68-2-2. The duration of the test shall last 72 hours. The rate of change in temperature shall be 10°C/hour.

The GPSR shall be able to start and operate properly at a low temperature of 0°C. Low temperature test procedures are defined in IEC 68-2-1. The duration of the test shall be 72 hours. The rate of change in temperature shall be 10°C/hour.

6.2 Humidity Range

The GPSR shall be capable of meeting all the electrical requirements outlined in Section 5 of this document over a relative humidity range of 5% to 95% (max 0.024 lbs of water per 1 lb of dry air). The test procedures are outlined in IEC 68-2-3 with a test duration of 4 days.

6.3 Altitude

The GPSR shall be capable of meeting all the electrical requirements outlined in Section 5 of this document over an elevation range or -60 metres below sea level to 4000 metres above sea level. The maximum operating temperature requirement shall be derated by 2 degrees C per 300 metres for altitudes beyond 1500 metres.

6.4 Operational Vibration Endurance

The vibration in the GPSR operational environment (ie: from nearby highway, rail track, etc.) shall not affect equipment performance. The GPSR shall meet the test conditions imposed by Bellcore GR-63 CORE^[1], Section 5.4.2., Alternative Test Procedure for Electronic Subassemblies Only. The swept sine frequency range shall be 5Hz to 200Hz.

6.5 Fungus Resistance

All GPSR components made from polymeric components shall have a fungus growth rate of zero as described and tested according to ASTM G-21.

6.6 Shipping and Storage

6.6.1 Temperature and Thermal Shock

The GPSR shall not sustain any damage or deterioration in functional performance after being exposed to storage temperatures of -55°C to $+85^{\circ}\text{C}$. The test method to be used is detailed in Bellcore document GR-63-CORE^[1] sections 5.1.1.1 and 5.1.1.2.

6.6.2 Humidity

The GPSR shall not sustain any damage or deterioration in functional performance after being exposed to 96 hours of 40C, 90% - 95% relative humidity. The test procedure guidelines are detailed in section 5.1.1.3. of the Bellcore document GR-63-CORE^[1].

6.6.3 Packaged Drop

The packaged GPSR should sustain no physical damage after being subjected to a series of free falls onto a hard surface in accordance with the test procedures in section 5.3.1 of the Bellcore document GR-63-CORE^[1].

6.6.4 Unpackaged Installer/Service Drop

The GPSR should not sustain any physical damage or deterioration on functional performance when subjected to unpackaged drop tests in accordance with the test procedures in section 5.3.2 of the Bellcore document GR-63-CORE^[1].

6.6.5 Shock Fragility

The packaged GPSR should sustain no physical or functional damage after being subjected to impact loads resulting from railroad car coupling. Product shall be subjected to 3 successive 50g, 11ms half sine shocks in each direction of three mutually perpendicular axes, in accordance with test procedures in IEC-68-2-27^[23], Test E2.

6.6.6 Transportation Vibration

A packaged GPSR will withstand loads applied by simulated transportation vibrations using procedures outlined in section 5.4.3, Curve 2, of the Bellcore document GR-63-CORE^[1]. This exposure shall not result in damage to, or loosening of, component parts.

6.6.7 Transportation Bounce

The packaged product shall function within specification after exposure to bounces of 1.1 to 1.2g, on 6 sides with a 90° horizontal rotation halfway through each side (180 minutes total test time). The test method to be used is IEC 68-2-55^[30], Method A.

7.0 Electromagnetic Environment

The GPSR shall meet all electromagnetic standards detailed in this section.

7.1 Radiated Emissions (Non Regulatory)

The GPSR shall not exceed 6 dB below the radiated emissions requirements for “doors closed”, class B equipment in sections 3.2.1 and 3.2.2 in the Bellcore document GR-1089-CORE^[4].

Also, the radiated emission levels should not exceed 6 dB below the objective specified in Bell Canada TAD 8465^[7] section E1B which is similar to GR-1089-CORE^[4] but with different limits depending on the distance.

7.2 Conducted Emissions

The conducted emissions levels on the AC/DC power on intersystem signal leads shall not exceed 3 dB below the limits specified in section 3.2.4 Class B limits in the Bellcore document GR-1089-CORE.

Conducted emissions on the GPSR antenna cable should not exceed levels 3 dB below the limits specified in GR-1089-CORE^[4], Section 3.2.4, as an objective only. This test, carried out on antenna cable, ensures that low frequency emissions that cannot be measured effectively at the Open Field Site are within limits that will not cause interference to adjacent electronics. The applicable frequency band is 10 kHz-30 MHz.

7.3 Indirect Electrostatic Discharge Immunity

The GPSR shall be immune to indirect ESD up to 8kV contact discharge (severity level 4) + 1kV margin with no perceptible disturbance in operation. This is defined in Bellcore GR-1089 CORE^[4], section 2.2 and the suitable test method is defined in IEC-801-2^[17] or Bell Canada Standard TAD8465^[7].

7.4 Direct Electrostatic Discharge Immunity

The GPSR shall be able to withstand direct ESD up to 15kV (severity level 4) + 15% margin air discharge and 8kV (severity level 4) + 1kV margin contact discharge with no perceptible disturbance in operation. This is defined in Bellcore GR-1089 CORE^[4], section 2.2 and the suitable test method is defined in IEC-801-2^[17] or Bell Canada Standard TAD8465^[7]. Also, ESD up to 20kV air discharge should not result in any hardware damage during operation or handling. All ports on the GPSR shall comply with this requirement.

7.5 Electrical Fast Transient

The GPSR shall withstand Electrical Fast Transients with no perceptible loss of operation when subjected to disturbance on power line or RF signal leads such as the Antenna port. The requirement is IEC-801-4 (level 2) + 20% margin with a suitable test method provided by that document.

7.6 Radiated Immunity

The GPSR shall meet the radiated immunity requirements with doors closed in section 3.3.1 of the Bellcore document GR-1089-CORE^[4] with a 3 dB test margin. The test procedure is detailed in section 3.5.

7.7 Conducted Immunity

The GPSR shall meet the conducted immunity requirements in section 3.3.3 of the Bellcore document GR-1089-CORE^[4] with a 3 dB test margin. The requirement apply only to the GPSR antenna lead. The test procedures are detailed in section 3.5.6 of Bellcore document GR-1089-CORE^[4].

7.8 Lightning Protection

The Polyphaser IS-MR50LNZ+6 surge protection device shall be used with the GPSR. This device shall serve as a bulkhead connection and ground between the antenna cable and the building where the CDMA system cabinet resides for indoor applications, or between the exterior and interior of the CDMA systems for outdoor applications.

8.0 Regulatory Requirements

8.1 General

All regulatory requirements and standards shall be met over any combination of the operating conditions outlined in Section 5 of this document for all GPSR configurations. The vendor is expected to provide the required documentation which demonstrates the products conformance to the following standards.

8.2 Electromagnetic Interference

8.2.1 Radiated Emissions

The GPSR shall comply with FCC part 15^[6] and ICES-003^[31]. CISPR 22^[13] Class B limits are objectives only. Emissions levels shall not exceed 6 dB below the limits specified.

8.3 Product Safety

The GPSR shall comply with the standard UL 1950^[9], with compliance to both US and Canadian requirements and Nortel Corporate Standard 9101.00^[8] Series, Product Safety Reference Data. The power input to the GPSR shall be considered as being provided by a Safety Extra Low Voltage. The UL and CSA marks/labels shall be provided as specified in Section 4.9.4.

8.4 Materials Flammability

All GPSR configurations shall comply with the customer expectations for flammability as specified by UL, CSA and ASTM. These requirements are defined in Bellcore GR-63-CORE^[1], Section 4.2, which includes the following:

Underwriter Laboratories (UL) Standard UL94.V-1^[10], with all printed circuit boards having a minimum 94.V-0 rating

ASTM D2863-77^[11] Oxygen Index of 28%

UL Standard UL94^[10], VW-1 on Cables

Tantalum capacitors shall not be used in the design to filter high current circuit such as power rails. Best telecom practises avoid the usage of tantalum capacitors because of the fire hazard they can introduce into the equipment.

8.5 Regulatory Submission and Maintenance

The OEM vendor will be responsible for testing and compiling all data necessary for obtaining initial IC / FCC regulatory and CSA/UL safety approvals. It is the responsibility of the OEM GPSR vendor to submit and maintain these filings.

9.0 Quality Assurance and Qualification

9.1 General

Requirements for quality assurance and qualification shall be in accordance with NPS50561, except as specified differently in the section.

9.2 Vendor Supplied Data

Each GPSR shall be supplied with the test data as proof of its performance. The test data shall consist of CPC, PEC, release, serial number, electrical parameters, and the name of person performing the test. The electrical parameters shall include power hysteresis, steady state power for power up mode, 1PPS accuracy of “on-time” edge, 1PPS jitter, 10MHz frequency accuracy over 24 hours for locked mode, 1PPS accumulated time error for holdover test mode.

A vendor supplied checklist is recommended to address workmanship issues such as visible scratches/paint chips, material deviation from design stocklist, label information and orientation, and visual inspection on the connectors.

9.3 Production Test Plan

The GPSR supplier testing shall be performed in accordance with the requirements specified within this document. GPSR testing shall be performed in accordance with a test plan and procedures developed by the supplier and approved by Nortel

9.4 Product Qualification Tests

Qualification testing shall consist of detailed measurements and environmental exposure to determine that the major components/subsystems performance characteristics have been achieved prior to conducting acceptance tests. Nortel reserves the right to witness and monitor the qualification tests to be conducted at the supplier’s facility or other Nortel approved locations. The test plan and procedures shall include specific pass/fail criteria and shall thoroughly demonstrate complete compliance of the equipment with all applicable performance specifications.

9.4.1 Test Methodology to Verify Holdover Capability

The following procedure outlines the test methods that shall be used to verify compliance of the 1 PPS signal to the $\pm 7 \mu\text{s}$ accumulated time error specification.

There shall be three tests performed that will encompass the 65°C operating range of the GPSR (see Table 3 for operating conditions). The entire temperature range shall not be covered in a single holdover test; rather, it is intended that a realistic diurnal cycle be used for both training and holdover purposes.

9.4.1.1 Holdover Test 1

Prior to the commencement of this test, it is mandatory that the GPSR under test be kept at room temperature for a period of 24 hours with no DC power applied to it. This is to permit the oscillator to cool completely and to simulate the conditions that the GPSR would encounter prior to installation at a cell site. The test conditions should also include the air flow that the GPSR will be exposed to under the operating conditions defined in Section 5.1.1.

The test data may be recorded visually using an oscilloscope to monitor the 1 PPS output of the GPSR under test against the 1 PPS output of a control GPSR that is kept locked to the GPS constellation throughout the entire 48 hour test period.

The test data may also be gathered automatically with a PC by forcing the GPSR under test into manual holdover after the 24 hour training period (without disconnecting the antenna) and monitoring the Time Interval for the 24 hours of holdover (see Section 5.1.9.3.29). This method allows the user to configure the necessary timers (in software), thus removing the need for constant supervision of the test process.

- Put the GPSR into the temperature chamber at 8C. Ensure that all required test connections are made.
- Activate the GPSR to start the test procedure.
- Ramp the temperature chamber down to 0C at -2°C/hour for four hours.
- Maintain 0C for four hours.
- Ramp the temperature chamber up to 20C at 3.3°C/hour for six hours.
- Maintain 20C for four hours.
- Ramp the temperature chamber down at -2°C/hour for six hours.
- Force the GPSR into holdover mode.
- Continue the temperature ramp at -2°C/hour for four hours, reaching 0C as a final temperature.
- Maintain 0C for four hours.
- Ramp the temperature chamber up to 30C at 10°C/hour for three hours.
- Maintain 30C for four hours.
- Ramp the temperature chamber down at -2°C/hour for nine hours.

- Record the deviation of the 1 PPS output. (If using an automated data collection method, a one-minute sampling interval is suggested for the 24 hour holdover period to permit a visual record to be constructed from the data.)

The test temperature cycle is also shown in the figure below.

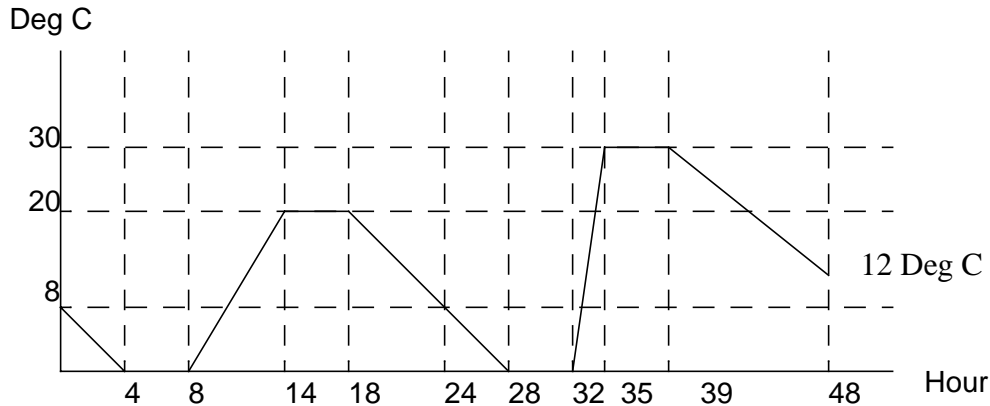

Figure 16: Temperature Cycle for Holdover Test 1

9.4.1.2 Holdover Test 2

Prior to the commencement of this test, it is mandatory that the GPSR under test be kept at room temperature for a period of 24 hours with no DC power applied to it. This is to permit the oscillator to cool completely and to simulate the conditions that the GPSR would encounter prior to installation at a cell site.

The test data may be recorded visually using an oscilloscope to monitor the 1 PPS output of the GPSR under test against the 1 PPS output of a control GPSR that is kept locked to the GPS constellation throughout the entire 48 hour test period.

The test data may also be gathered automatically with a PC by forcing the GPSR under test into manual holdover after the 24 hour training period (without disconnecting the antenna) and monitoring the Time Interval for the 24 hours of holdover (see Section 5.1.13.3.27). This method allows the user to configure the necessary timers (in software), thus removing the need for constant supervision of the test process.

- Put the GPSR into the temperature chamber at 28C. Ensure that all required test connections are made.
- Activate the GPSR to start the test procedure.
- Ramp the temperature chamber down to 20C at -2°C/hour for four hours.
- Maintain 20C for four hours.
- Ramp the temperature chamber up to 40C at 3.3°C/hour for six hours.
- Maintain 40C for four hours.
- Ramp the temperature chamber down at -2°C/hour for six hours.
- Force the GPSR into holdover mode.
- Continue the temperature ramp at -2°C/hour for four hours, reaching 20C as a final temperature.
- Maintain 20C for four hours.
- Ramp the temperature chamber up to 50C at 10°C/hour for three hours.
- Maintain 50C for four hours.
- Ramp the temperature chamber down at -2°C/hour for nine hours.
- Record the deviation of the 1 PPS output. (If using an automated data collection method, a one-minute sampling interval is suggested for the 24 hour holdover period to permit a visual record to be constructed from the data.)

The test temperature cycle is illustrated in the figure below.

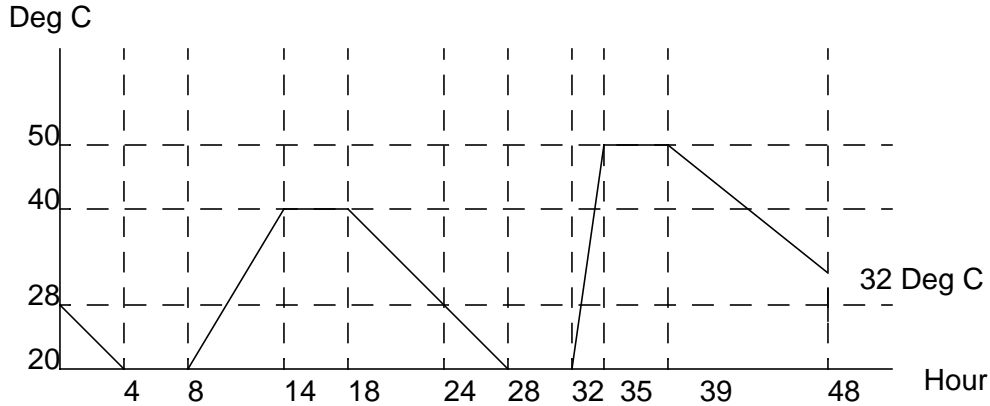

Figure 17: Temperature Cycle for Holdover Test 2

9.5 Acceptance Testing

Each deliverable GPSR, when fabricated, shall undergo acceptance testing to verify proper workmanship, identify manufacturing defects and determine that all components of the GPSR function properly before delivery. Each GPSR shall undergo a TBD-hour burn-in test at TBD C.

9.6 Traceability

For auditing purposes, the GPSR supplier shall retain all original notes, test data and prototypes for a period of one calendar year. The production test data shall be stored electrically for up to one year. The supplier shall supply this information to Nortel, FCC, IC, or CSA when requested.

9.7 Reliability Monitor

The supplier shall establish a reliability program which provides for environmental stress testing on a sample basis. The test results shall be made available to Nortel upon request.

9.8 Design Inspection

The GPSR supplier shall provide detailed design schematics of all interface circuitry to Nortel for purposes of design inspection.

9.9 Workmanship Evaluation

The GPSR shall be dismantled, where necessary, to allow inspection. The GPSR shall conform to NPS50561.

10.0 Preparation For Delivery

10.1 Packaging

Items covered by this specification shall be packaged in a manner which will provide protection against damage during shipment, handling and storage in reasonably dry, unheated quarters. Packing shall be in accordance with NPS50561.

10.2 Product Packaging Label

A packaging label must be clearly present on each shipping carton in human readable and in bar code format. This label must be visible when packages are stacked.

The product packaging label in bar code format shall include:

- Nortel Common Product Code (A0681847), compliant to the guidelines defined in Nortel Corporate Standard 9017.00, Vendor Labels.
- Nortel Product Engineering Code (NTPX26AB), compliant to the guidelines defined in Nortel Corporate Standard 9017.00, Vendor Labels.
- Nortel Current Release (Rel XX), compliant to the guidelines defined in Nortel Corporate Standard 9017.00, Vendor Labels where XX is a two-digit number assigned by Nortel Component engineering.
- Product manufacturing date code. Refer to Section 4.9.1.
- Quantity contained in the shipping carton

The product identification label for the shipping carton of the GPSR will include, in human readable format:

- Vendor name
- Product Description: GPSR Dual Polarity
- Lot number
- Nortel purchase order number

10.3 Operation Manual

The vendor shall provide a copy of an operation manual with each GPSR. The implementation of the requirement shall be negotiated between Nortel and the vendor.

The manual shall include the following items as the minimum requirements. It is at the discretion of the vendor to provide further information.

- Product description and Options

- Accessories
- Field commission tools
- User's manual
- Vendor's available documentations

- Getting started

- Front panel and rear panel drawings
- Preparation of the GPSR for use (antenna system, cable assembly, PC configuration, field commissioning software installation, etc.)
- Power-up the GPSR and load the field commissioning tool.
- Brief explanation of the software tool and the graphical interface menu
- Operation of the software tool

- Product features and functions

- Front panel indicators
- Hardware interface (input, output, serial interface)
- General operation concepts (acquisition, normal, holdover, recovery, etc.)
- Detailed field commissioning tool menu and features

- Available SCPI commands and responses listing, error messages, and Internal register mappings

- Product Specifications

10.4 Commissioning Tool

The vendor shall provide a copy of a software tool for field commissioning purposes with each GPSR. The implementation of this requirement shall be negotiated between Nortel and the vendor.

11.0 Product Changes

A baseline used to categorize important changes (from Nortel's perspective) to the GPSR will be defined during product qualification. This baseline will categorize the relevant changes into the following groups;

- Production Process
- Test Process
- Critical Components such as oscillators, GPS engine, DAC, etc.
- Module Pass/Fail Criteria

The substance within each of the four groups will be derived from the manufacturing plan developed jointly by Nortel and the vendor. Any changes to the module which are directly referred to in the baseline criteria must be submitted to Nortel for approval. Nortel must be informed of all other changes which fall outside of the baseline.

12.0 Reliability Assurance

The intent of this section to define the reliability and quality requirements for this product and to ensure that it will be able to meet all technical specifications through its life time.

12.1 Reliability

The GPSR shall have a minimum calculated MTBF of greater than 250000 hours when operated in a ground, fixed, uncontrolled environment as defined in Bellcore document TR-NWT-000332, Issue 4, at an ambient temperature of 40C. The vendor shall use Bellcore Method I for these calculations.

12.2 Eliminating Infant Mortality Failures

The vendor must implement a program/process in production to minimize infant mortality of this product. Production units must pass all functional specifications. The expectation is to encounter no more than one failure per specified lot or 1% failure of total production per month. If failures occur, they must be analyzed, root cause must be determined, and corrective action must be implemented.

12.3 Statistical Product Monitoring

The vendor will implement Statistical Process Monitoring during production testing. The supplier must provide a monthly report of Cpk values on critical parameters. Cpk values will be measured on the top three critical parameters of this product.

12.4 Field Performance Monitoring

The supplier will track and document all field performance data on all deployed products to customers. In the occurrence of a product failure in the field, Nortel will transfer all failed units to the vendor for failure analysis.

The supplier will failure analyze the failed units and release a report, to Nortel, describing the failures which were found. The report should include a failure log, a "Time to Failure Plot", and a Pareto of failure causes and the corrective action to be implemented.

12.5 Product Reliability Growth

During the ongoing manufacturing of this product, it is expected, as part of a joint commitment to quality products, that the supplier demonstrate a continual product reliability growth. The supplier will provide information to demonstrate ongoing product reliability growth.

This can be accomplished by design improvements (within the form, fit and function of the product specification) improved manufacturing processes, new suppliers, or by any means the supplier so chooses.

A report is required monthly that illustrates the current reliability level and a list of actions that were used to create growth.

12.6 Yield Improvement Program

The supplier must continually identify the five top reasons for poor yield on this product and take the appropriate steps to address these issues.